

B Series Temperature Controller Instruction Sheet

Thank you very much for purchasing DELTA B Series. Please read this instruction sheet before using your B series to ensure proper operation and please keep this instruction sheet handy for quick reference.

1 Precaution

DANGER! Caution! Electric Shock!

- Do not touch the AC terminals while the power is supplied to the controller to prevent an electric shock.
- Make sure power is disconnected while checking the unit inside.

- The symbol  indicates that this Delta B Series Temperature Controller is protected throughout by DOUBLE INSULATION or REINFORCED INSULATION (equivalent to Class II of IEC 536).

WARNING!

This controller is an open-type temperature controller. Make sure to evaluate any dangerous application in which a serious human injury or serious property damage may occur.

- Always use recommended solder-less terminals: Fork terminal with isolation (M3 screw, width is 7.0mm (6.0mm for DTB 4824), hole diameter 3.2mm). Screw size: M3 x 6.5 (With 6.8 x 6.8 square washer). Screw size for DTB4824: M3 x 4.5 (With 6.0 x 6.0 square washer). Recommended tightening torque: 0.4 N.m (4kgf.cm). Applicable wire: Solid/twisted wire of 2 mm², 12AWG to 24AWG. Please be sure to tighten them properly.
- Do not allow dust or foreign objects to fall inside the controller to prevent it from malfunctioning.
- Never modify or disassemble the controller.
- Do not connect anything to the "No used" terminals.
- Make sure all wires are connected to the correct polarity of terminals.
- Do not install and/or use the controller in places subject to:
 - Dust or corrosive gases and liquid.
 - High humidity and high radiation.
 - Vibration and shock.
 - High voltage and high frequency
- Must turn power off when wiring and changing a temperature sensor.
- Be sure to use compensating wires that match the thermocouple types when extending or connecting the thermocouple wires.
- Purge use wires with resistance when extending or connecting a platinum resistance thermometer (RTD).
- Please keep the wire as short as possible when wiring a platinum resistance thermometer (RTD) to the controller and please route power wires as far as possible from load wires to prevent interference and induced noise.
- This controller is an open-type unit and must be placed in an enclosure away from high temperature, humidity, dripping water, corrosive materials, airborne dust and electric shock or vibration.
- Please make sure power cables and signals from instruments are all installed properly before energizing the controller, otherwise serious damage may occur.
- Please do not touch the terminals in the controller or try to repair the controller when power is applied to prevent an electric shock.
- Wait at least one minute after power is disconnected to allow capacitors to discharge, and please do not touch any internal circuit within this period.
- Do not use acid or alkaline liquids for cleaning. Please use a soft, dry cloth to clean the controller.
- This instrument is not furnished with a power switch or fuse. Therefore, if a fuse or power switch is required, install the protection close to the instrument. Recommended fuse rating: Rated voltage 250 V, Rated current 1 A. Fuse type: Time-lag fuse
- Note: This controller does not provide overcurrent protection. Use of this product requires that suitable overcurrent protection device(s) must be added to ensure compliance with all relevant electrical standards and codes. (Rated 250 V, 15 Amps max). A suitable disconnecting device should be provided near the controller in the end-use installation.

2 Display, LED and Pushbuttons



PV Display : to display the process value or parameter type.

SV Display : to display the set point, parameter operation read value, manipulated variable or set value of the parameter.

AT : Auto-tuning LED, flashes when the Auto-tuning operation is ON.

OUT1/OUT2 : Output LED, lights when the output is ON.

SET : **Function key**. Press this key to select the desired function mode and confirm a setting value.

Mode key. Press this key to set parameters within function mode.

Temperature unit LED. °C : Celsius °F : Fahrenheit

ALM1 ~ ALM3 : Alarm output LED, lights when ALM1/ALM2/ALM3 is ON.

Down key. Press this key to decrease values displayed on the SV display. Hold down this key to speed up the decrements.

Up key. Press this key to increase values displayed on the SV display. Hold down this key to speed up the incremental action.

3 Ordering Information

DTB Series	DTB 1 2 3 4 5 6 7
DTB Series	DTB : Delta B Series Temperature Controller
1 2 3 4 Panel Size (W×H)	4824 : 1/32 DIN W48 × H24mm 4848 : 1/16 DIN W48 × H48mm 4896 : 1/8 DIN W48 × H96mm 9696 : 1/4 DIN W96 × H96mm
5 1st Output Group Selection	R: Relay output, SPDT (SPST: 1/16 DIN and 1/32 DIN size), 250VAC, 5A V: Voltage pulse output, 14V +10% ~ -20% (Max. 40mA) C: DC current output, 4 ~ 20mA L: Linear voltage output, 0~5V, 0~10Vdc
6 2nd Output Group Selection	R: Relay output, SPDT (SPST: 1/16 DIN and 1/32 DIN size), 250VAC, 5A V: Voltage pulse output, 14V +10% ~ -20% (Max. 40mA)
7 EVENT Inputs / CT function (Optional)	None : No EVENT input, No CT (Current transformer) E: EVENT input is provided, No CT (Current transformer) T: CT (Current transformer) is provided, No EVENT input

Note 1 : DTB4824 series: no optional function provided and no extra alarm output supported, but user can set 2nd output as alarm mode

Note 2 : DTB4848 series: only one alarm output when optional function supported, but user can set 2nd output as 2nd alarm output

4 Specifications

Input Voltage	100 to 240VAC 50/60Hz
Operation Voltage Range	85% to 110% of rated voltage
Power Consumption	5VA max.
Memory Protection	EEPROM 4K bit (non-volatile memory (number of writes: 100,000))
Display Method	2 line x 4 character 7-segment LED display Process value(PV): Red color, Set point(SV): Green color
Sensor Type	Thermocouple: K, J, T, E, N, R, S, B, L, U, TXK 3-wire Platinum RTD: Pt100, JPt100
Control Mode	Analog input: 0~5V, 0~10V, 0~20 mA, 4~20 mA, 0~50mV PID, ON/OFF, Manual or PID program control (Ramp/Soak control)
Control Output	Relay output: SPDT (SPST: 1/16 DIN and 1/32 DIN size), Max. load 250VAC, 5A resistive load Voltage pulse output: DC 14V, Max. output current 40mA Current output: DC 4 ~ 20mA output (Load resistance: Max. 600Ω) Linear voltage output: 0~5V, 0~10V
Display Accuracy	0 or 1 digit to the right of the decimal point (selectable)
Sampling Rate	Analog input: 150 msec/ per scan Thermocouple or Platinum RTD: 400 msec/per scan
RS-485 Communication	MODBUS ASCII / RTU communication protocol
Vibration Resistance	10 to 55Hz, 10m/s ² for 10min, each in X, Y and Z directions
Shock Resistance	Max. 300m/s ² , 3 times in each 3 axes, 6 directions

Ambient Temperature	0 °C to +50 °C
Storage Temperature	-20 °C to +65 °C
Altitude	2000m or less
Relative Humidity	35% to 85% (non-condensing)

5 Temperature Sensor Type and Temperature Range

Input Temperature Sensor Type	Register Value	LED Display	Temperature Range
0~50mV Analog Input	17	0.0	-999 ~ 9999
4~20mA Analog Input	16	0.04	-999 ~ 9999
0~20mA Analog Input	15	0.00	-999 ~ 9999
0V~10V Analog Input	14	0.10	-999 ~ 9999
0V~5V Analog Input	13	0.05	-999 ~ 9999
Platinum Resistance (Pt100)	12	Pt	-200 ~ 600°C
Platinum Resistance (JPT100)	11	JPt	-20 ~ 400°C
Thermocouple TXK type	10	TXK	-200 ~ 800°C
Thermocouple U type	9	U	-200 ~ 500°C
Thermocouple L type	8	L	-200 ~ 850°C
Thermocouple B type	7	B	100 ~ 1800°C
Thermocouple S type	6	S	0 ~ 1700°C
Thermocouple R type	5	R	0 ~ 1700°C
Thermocouple N type	4	N	-200 ~ 1300°C
Thermocouple E type	3	E	0 ~ 600°C
Thermocouple T type	2	T	-200 ~ 400°C
Thermocouple J type	1	J	-100 ~ 1200°C
Thermocouple K type	0	K	-200 ~ 1300°C

Note 1 : An external 250Ω precision resistor should be connected when the current input is selected as the input temperature sensor type..

Note 2 : **SP** (Operation mode) must be set if user wish to specify decimal point position. Except for the thermocouple B, S, R type, the decimal point positions of all the other thermocouple type input sensors can be set.

The default range of analog input is -999 ~ 9999. For example, when a 0~20mA analog input is selected as the input temperature sensor type, -999 indicates 0mA and 9999 indicates 20mA. If change the input range to 0 ~ 2000, then 0 indicates 0mA and 2000 indicates 20mA. One display scale is equal to 0.01mA.

6 Operation

There are three modes of operation: operation, regulation and initial setting. When power is applied, controller gets into the operation mode.

Press the **SET** key to switch to regulation mode. If the **SET** key is pressed for more than 3 seconds, controller will switch to the initial setting mode. Pressing the **SET** key while in the regulation mode or initial setting mode, forces the controller to return to the operation mode. PV/SV:

Sets the temperature set point and displays the temperature process value. Use **▲** **▼** keys to set the temperature set point.

Setting method: While in any function mode, press the **MODE** key to select the desired function and use the **▲** **▼** keys to change settings. Press **SET** key to save the changes. The next flow chart shows how to switch for settings and internal functions:

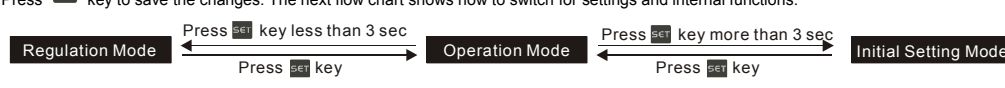

Regulation Mode	Operation Mode	Initial Setting Mode
AT Auto-tuning (Set in PID control and RUN mode) Press MODE ↓	1234 Use ▲ ▼ key to set temperature set point Press MODE ↓	0.0Pt Set input type Press MODE ↓
P Set PID PB value (Set in PID control mode) Press MODE ↓	r-s Control setting RUN or STOP Press MODE ↓	0.00u Set temperature unit do not display when analog input Press MODE ↓
Ti Set PID Ti value (Set in PID control mode) Press MODE ↓	Prn Start pattern setting (Set in PID program control mode) Press MODE ↓	0.0H Set upper-limit of temperature range Press MODE ↓
Td Set PID Td value (Set in PID control mode) Press MODE ↓	SP Decimal point position selection (except for B, S, R type, all the other types can be set) Press MODE ↓	0.0L Set lower-limit of temperature range Press MODE ↓
Pdof or ioF PD/PID control offset setting (When PID control is ON and Ki=0, set the value of Pdof; If Ki≠0, AT will automatically set the value of ioF) Press MODE ↓	ALH Upper-limit alarm 1 (This parameter is available only when ALA1 function enables) Press MODE ↓	Ctrl Select control mode (When select PID program control, it will enter step editing selection, refer to the table below) Press MODE ↓
HES Heating hysteresis setting (Set in ON/OFF control mode) Press MODE ↓	ALL Lower-limit alarm 1 (This parameter is available only when ALA1 function enables) Press MODE ↓	5-HC Select heating/cooling control or dual loop output control Press MODE ↓
CS Cooling hysteresis setting (Set in ON/OFF control mode) Press MODE ↓	AL2H Upper-limit alarm 2 (This parameter is available only when ALA2 function enables) Press MODE ↓	ALA1 Alarm 1 mode setting Press MODE ↓
HEPd or CLPd Heating/Cooling control cycle setting (Set in PID control mode) Press MODE ↓	AL2L Lower-limit alarm 2 (This parameter is available only when ALA2 function enables) Press MODE ↓	ALA2 Alarm 2 mode setting Press MODE ↓
HEPd Control cycle setting of 2nd output group (Set in PID control and Dual Loop output control mode) Press MODE ↓	AL3H Upper-limit alarm 3 (This parameter is available only when ALA3 function enables) Press MODE ↓	ALA3 Alarm 3 mode setting Press MODE ↓
ioEF P value of 1st & 2nd output group during dual loop output control P value of 2nd output group = (P value of 1st output group) x ioEF Press MODE ↓	AL3L Lower-limit alarm 3 (This parameter is available only when ALA3 function enables) Press MODE ↓	SALA Set system alarm Press MODE ↓

dBd Dead Band (Set in Dual Loop output control mode) Press MODE ↓	LoL Setting lock mode Press MODE ↓	CoSH Communication write function enable/disable Press MODE ↓
0.0PoF Regulate temperature deviation value Press MODE ↓	0.001 Display and adjust output value of 1st output group (Display in PID control mode and manual RUN mode) Press MODE ↓	0-5L ASCII, RTU communication format selection Press MODE ↓
0.0HL Regulate upper-limit of analog output value (The setting display when analog output) Press MODE ↓	0.002 Display and adjust output value of 2nd output group (Display in dual loop PID control mode and manual RUN mode) Press MODE ↓	0-no Communication address setting Press MODE ↓
0.0Lo Regulate lower-limit of analog output value (The setting display when analog output) Press MODE to return to auto-tuning mode	0.0 In case of using an external CT, the controller displays the current value being measured by CT, if the control output is ON Press MODE to return to set target temperature	0.05 Communication baud rate setting Press MODE ↓

* 1 Scale = 2.8uA = 1.3mV for tuning output value

LEn Data length setting Press MODE ↓	Parity Parity bit setting Press MODE ↓	Stop Stop bit setting Press MODE to return input type setting
---	---	--

Pattern and step editing selection: edit **Prn** in **Ctrl** parameter. The following display is the example operation of pattern No. 0.

Prn Select desired editing pattern number select OFF Press MODE ↓ 0 select number	SP00 Edit temperature of step No. 0 of pattern No. 0 Press MODE ↓	PS00 Select actual step No. when program control is executing Press MODE ↓
Exit pattern and step editing selection Switch to 5-HC and continue setting	0.00 Edit time of step No. 0 of pattern No. 0, unit is hh.mm Press MODE ↓	0.00 Set additional execution cycle number(0 to 99) Press MODE ↓
	Set step No. 07 in order	SP07 Set link pattern, OFF indicates the program end Press MODE to return pattern No. editing mode
	SP07 Edit temperature of step No. 7 of pattern No. 0 Press MODE ↓	
	0.07 Edit time of step No. 7 of pattern No. 0, unit is hh.mm Press MODE to set actual step No.	

7 Dual Loop Output Control (Heating / Cooling Control)

Temperature control can be achieved either by heating or cooling. In DTB series, heating and cooling can be operated simultaneously (Dual Loop output control) to perform temperature control. When Dual Loop output control are used, two control outputs must be connected to the heating and cooling devices. Please refer to the following for the operation:

5-HC : This parameter is used to select heating or cooling action if operate

either heating or cooling function in this controller. When selecting **HERE**, 1st

output group is heating (reverse) control, and when selecting **COOL**, 1st

output group is cooling (forward) control. At this moment, 2nd output group is

regarded as an alarm output. If user select **HIC2** or **CH2**, it indicates

that user can operate Dual Loop output control function in this controller. When

selecting **HIC2**, 1st output group is heating (reverse) control and 2nd output

group is cooling (forward) control. When selecting **CH2**, 1st output group is

cooling (forward) control and 2nd output group is heating (reverse) control.

In DTB series, P(Proportional Band), I(Integral Time) and D(Derivative Time)

parameters are automatically set by using the Auto-tuning (AT) function.

ioEF : This parameter is for the control mode that must be Dual Loop output

control with PID control method configured. The value of P, I and D of 1st output

group can be set immediately. The P value of 2nd output group is equal to (P

value of 1st output group) x **ioEF** and the value of I and D of 2nd output group

are the same as the value of I and D of 1st output group.

dBd : Dead Band, shown as the following figure 1, 2 and 3. This parameter

sets an area in which the heating and cooling control output is 0 centering around

the set point in a Dual Loop output control mode.

LoL : **Settings lock**. To avoid incorrect operation, two key lock functions are provided. **LoL1** : Lock 1 can lock all settings. All



parameters and temperature settings can be locked to disable changes. **LoL2** : Lock 2 can lock settings except the SV (Set point) value. All

parameters and temperature settings can be locked with the exception of the SV value. Press **SET** and **MODE** key simultaneously, the "Lock" status can be released.

8 Alarm Outputs

There are up to three groups of alarm outputs and each group allows thirteen alarm types in the initial setting mode. The alarm

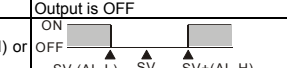
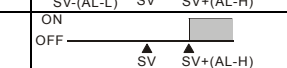
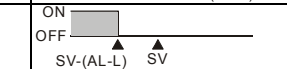
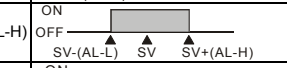
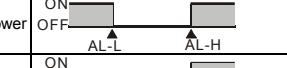
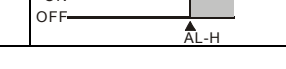
output is activated whenever the process temperature value (PV) is getting higher or lower than the set point of alarm limit.

Set Value	Alarm Type	Alarm Output Operation
0	Alarm function disabled	Output is OFF
1	Deviation upper- and lower-limit: This alarm output operates when PV value is higher than the setting value SV+(AL-H) or lower than the setting value SV-(AL-L).	ON:  OFF: 
2	Deviation upper-limit: This alarm output operates when PV value is higher than the setting value SV+(AL-H).	ON:  OFF: 
3	Deviation lower-limit: This alarm output operates when PV value is lower than the setting value SV-(AL-L).	ON:  OFF: 
4	Reverse deviation upper- and lower-limit: This alarm output operates when PV value is in the range of the setting value SV+(AL-H) and the setting value SV-(AL-L).	ON:  OFF:
5	Absolute value upper- and lower-limit: This alarm output operates when PV value is higher than the setting value AL-H or lower than the setting value AL-L.	ON: OFF:
6	Absolute value upper-limit: This alarm output operates when PV value is higher than the setting value AL-H.	ON: OFF:

7	Absolute value lower-limit: This alarm output operates when PV value is lower than the setting value AL-L.	ON OFF	
8	Deviation upper- and lower-limit with standby sequence: This alarm output operates when PV value reaches set point (SV value) and the value is higher than the setting value SV+(AL-H) or lower than the setting value SV-(AL-L).	ON OFF	
9	Deviation upper-limit with standby sequence: This alarm output operates when PV value reaches set point (SV value) and the reached value is higher than the setting value SV+(AL-H).	ON OFF	
10	Deviation lower-limit with standby sequence: This alarm output operates when PV value reaches the set point (SV value) and the reached value is lower than the setting value SV-(AL-L).	ON OFF	
11	Hysteresis upper-limit alarm output: This alarm output operates if PV value is higher than the setting value SV+(AL-H). This alarm output is OFF when PV value is lower than the setting value SV-(AL-L).	ON OFF	
12	Hysteresis lower-limit alarm output: This alarm output operates if PV value is lower than the setting value SV-(AL-H). This alarm output is OFF when PV value is higher than the setting value SV-(AL-L).	ON OFF	
13	CT alarm output: This alarm operates when the current measured by transformer (CT) is lower than AL-L or higher than AL-H (This alarm output is available only for the controller with current transformer).	ON OFF	

(Note: AL-H and AL-L include AL1H, AL2H, AL3H and AL1L, AL2L, AL3L.)

9 Current Transformer (CT) Function

The Current Transformer (CT) function is used with the alarm output. When using a current transformer (CT) with the controller, change the corresponding alarm output mode to mode 13 (alarm output set value is 13), then turn to operation mode and set the current lower-limit and current upper-limit. You can set current alarm range between 0.5A ~ 30A, display resolution is 0.1A and measure accuracy is +/- 0.5A.

10 EVENT Inputs Function

There are two optional event inputs (contact inputs) supported (EVENT1 and EVENT2) in DTB series.

EVENT1 : RUN/STOP operation can be executed by RUN/STOP parameters (Operation Mode) or via the communication. User also can control RUN/STOP operation by EVENT 1 in DTB series. The control output is ON if the circuit of EVENT 1 is open when the controller is operating. Otherwise, the controller will stop output if the circuit of EVENT 1 is short or when the system parameter of the controller is set to STOP mode.

EVENT2 : DTB series allows user can switch two temperature setting value by changing the status (open/short) of EVENT 2. Each temperature setting value has independent control parameters.

11 PID Control (Ramp/Soak Program Control)

Description of Function and Parameters Setting:

PID program control by 8 patterns (Pattern No. 0~7) is supported in DTB series. Each pattern contains 8 steps (step No. 0 ~ 7), one Link Pattern parameter, one Cycle parameter and one Actual Step parameter

Start Pattern : P_{Start} is in operation mode and it is used to set the Start Pattern of PID program control (This parameter appear in STOP mode only).

Steps : Include set point X and execution time T, these two parameters setting. The set point (SV) should reach temperature X after the period of execution time T. If the set point is the same as the result of the previous setting, then it is called Soak program control. If not, then it is called Ramp program control. Therefore, PID program control is also called Ramp/Soak program control.

The default of step No. 0 in this controller is Soak program control. The controller will control the temperature (PV) to reach the set point X and then keep the temperature at set point X. The period of execution time is time T which provided by .step No. 0.

Link Pattern Parameter : For example, when set L_{Cn0} to 2, it indicates that pattern No. 2 will execute next after the execution of pattern No. 0. If set to off , it indicates the program will stop after executing the current pattern and the temperature will keep at the set point of the last step.

Cycle Parameter : Additional execution cycle number. For example, when set C_{Cn4} to 2, it indicates that pattern No. 4 should execute twice in addition. Include origin one time execution, total execute three times.

Actual Step Parameter : Execution step number per pattern (can set to 0 ~ 7). For example, when set P_{Sct7} to 2, it indicates that pattern No 7 will not execute other steps than step 0 to step2.

Execution : When $r-s$ is set to run , the program will start to execute in order from the step 0 of start pattern.

When $r-s$ is set to $stop$, the program will stop and the control output is disabled.

When $r-s$ is set to $setp$, the program will stop and the temperature at that time will be controlled at the set point before program stop. Select run again, then the program will restart and execute from step 0 of start pattern.

When $r-s$ is set to $phod$, the program will stop and the temperature at that time will be controlled at the set point before program stop. Select run again, then the program will follow the step before stop and start to execute through the rest of the time.

Display : During PID program control, the SV default display is P-XX, P indicates the current execution pattern and XX indicates the current execution step. Press \checkmark to change the display item.

After select SP , press SET key, and then the temperature set point of the current execution step will display on SV display.

After select $r-tc$, press SET key, and then the residual time of the current execution step will display on SV display.

12 RS-485 Communication

1. Supporting transmission speed: 2400, 4800, 9600, 19200, 38400bps
2. Non-supported formats: 7, N, 1 or 8, O, 2 or 8, E, 2
3. Communication protocol: Modbus (ASCII or RTU)
4. Function code: 03H to read the contents of register (Max. 8 words), 06H to write 1 (one) word into register, 02H to read the bits data (Max. 16 bits), 05H to write 1 (one) bit into register.
5. Address and Content of Data Register:

Address	Content	Explanation
1000H	Process value (PV)	Measuring unit is 0.1, updated one time in 0.4 second The following reading value display indicates error occurs: 8002H : Initial process (Temperature value is not got yet) 8003H : Temperature sensor is not connected 8004H : Temperature sensor input error 8006H : Cannot get temperature value, ADC input error 8007H : Memory read/write error
1001H	Set point (SV)	Unit is 0.1, °C or °F
1002H	Upper-limit of temperature range	The data content should not be higher than the temperature range
1003H	Lower-limit of temperature range	The data content should not be lower than the temperature range
1004H	Input temperature sensor type	Please refer to the contents of the "Temperature Sensor Type and Temperature Range" for detail
1005H	Control method	0: PID, 1: ON/OFF, 2: manual tuning, 3: PID program control
1006H	Heating/Cooling control selection	0: Heating, 1: Cooling, 2: Heating/Cooling, 3: Cooling/Heating
1007H	1st group of Heating/Cooling control cycle	1 to 99 seconds
1008H	2nd group of Heating/Cooling control cycle	1 to 99 seconds
1009H	PB Proportional band	0.1 ~ 999.9
100AH	Ti Integral time	0~9999
100BH	Td Derivative time	0~9999
100CH	Integration default	0~100%, unit is 0.1%
100DH	Proportional control offset error value, when Ti = 0	0~100%, unit is 0.1%
100EH	The setting of COEF when Dual Loop output control are used	0.01 ~ 99.99
100FH	The setting of Dead band when Dual Loop output control are used	-999 ~ 9999
1010H	Hysteresis setting value of the 1st output group	0 ~ 9999
1011H	Hysteresis setting value of the 2nd output group	0 ~ 9999
1012H	Output value read and write of Output 1	Unit is 0.1%, write operation is valid under manual tuning mode only.
1013H	Output value read and write of Output 2	Unit is 0.1%, write operation is valid under manual tuning mode only.

1014H	Upper-limit regulation of analog linear output	1 Unit = 2.8uA(Current Output) = 1.3mV(Linear Voltage Output)
1015H	Lower-limit regulation of analog linear output	1 Unit = 2.8uA(Current Output) = 1.3mV(Linear Voltage Output)
1016H	Temperature regulation value	-127 ~ +127, unit is 0.1
1017H ~ 101FH	Reserved	
1020H	Alarm 1 type	Please refer to the contents of the "Alarm Outputs" for detail
1021H	Alarm 2 type	Please refer to the contents of the "Alarm Outputs" for detail
1022H	Alarm 3 type	Please refer to the contents of the "Alarm Outputs" for detail
1023H	System alarm setting	0: None (default), 1~3: Set Alarm 1 to Alarm 3
1024H	Upper-limit alarm 1	Please refer to the contents of the "Alarm Outputs" for detail
1025H	Lower-limit alarm 1	Please refer to the contents of the "Alarm Outputs" for detail
1026H	Upper-limit alarm 2	Please refer to the contents of the "Alarm Outputs" for detail
1027H	Lower-limit alarm 2	Please refer to the contents of the "Alarm Outputs" for detail
1028H	Upper-limit alarm 3	Please refer to the contents of the "Alarm Outputs" for detail
1029H	Lower-limit alarm 3	Please refer to the contents of the "Alarm Outputs" for detail
102AH	Read LED status	b0: Alm3, b1: Alm2, b2: F, b3: C, b4: Alm1, b5: OUT2, b6: OUT1, b7: AT
102BH	Read pushbutton status	b0: Set, b1: Select, b2: Up, b3: Down, 0 is to push
102CH	Setting lock status	0: Normal, 1: All setting lock, 11: Lock others than SV value
102FH	Software version	V1.00 indicates 0x100
1030H	Start pattern number	0 ~ 7
1040H~1047H	Actual step number setting inside the correspond pattern	0 ~ 7 = N, indicate that this pattern is executed from step 0 to step N
1050H~1057H	Cycle number for repeating the execution of the correspond pattern	0 ~ 99 indicate that this pattern has been executed for 1 ~ 100 times
1060H~1067H	Link pattern number setting of the correspond pattern	0 ~ 8, 8 indicates the program end, 0~7 indicates the next execution pattern number after executing the current pattern
2000H~203FH	Pattern 0~7 temperature set point setting Pattern 0 temperature is set to 2000H~2007H	-999 ~ 9999
2080H~208FH	Pattern 0~7 execution time setting Pattern 0 time is set to 2080H~2087H	Time 0 ~ 9999 (each one scale is 1 minute)

6.	Address and Content of Bit Register: (First bit of reading will put into LSB, Write data = FF00H for bit set, 0000H for bit clear)	Communication write-in selection	Communication write in disabled: 0 (default), Communication write in enabled: 1
0810H	Communication write-in selection	Temperature unit display selection	°C / linear input (default) : 1, °F : 0
0811H	Temperature unit display selection	Decimal point position selection	Except for the thermocouple B, S, R type, all the other thermocouple type are valid. (0 or 1)
0812H	Decimal point position selection	AT setting	OFF: 0 (default), ON : 1
0813H	AT setting	Control RUN/STOP setting	0: STOP, 1: RUN (default)
0814H	Control RUN/STOP setting		

7. Communication Transmission Format : Command Code: 02: read N bits, 05: write 1 bits, 03: read N words, 06: write 1 words
8. STX (Communication Start), ADR (Communication Address), CMD (Command Codes)

ASCII mode:

Read Command Message	Read Command Response Message	Write Command Message	Write Command Response Message
STX	STX	STX	STX
ADR 1	ADR 1	ADR 1	ADR 1
ADR 0	ADR 0	ADR 0	ADR 0
CMD 1	CMD 1	CMD 1	CMD 1
CMD 0	CMD 0	CMD 0	CMD 0
Starting data address	Number of data (Count by byte)	Write data address	Write data address
Number of data (Count by word/Bit)	Content of data address	Write data content	Write data content
LRC CHK 1	1000H/081xH	LRC CHK 1	LRC CHK 1
LRC CHK 0	1001H	LRC CHK 0	LRC CHK 0
END 1	CR CR	END 1	CR CR
END 0	LF LF	END 0	LF LF

LRC (Longitudinal Redundancy Check):
LRC check is the added sum from "Address" to "Data content". For example, 01H + 03H + 10H + 00H + 00H + 02H = 16H, then take the complementary of 2, EA.

RTU mode:

Read Command Message	Read Command Response Message	Write Command Message	Write Command Response Message
ADR	ADR	ADR	ADR
CMD	CMD	CMD	CMD
Starting address of read data	Number of data (Count by byte)	Write data address	Write data address
Number of data (Count by word/Bit)	Data content 1	Write data content	Write data content
CRC CHK Low	Data content 2	CRC CHK Low	CRC CHK Low
CRC CHK High	CRC CHK High	CRC CHK High	CRC CHK High
	CRC CHK Low		
	CRC CHK High		

CRC (Cyclical Redundancy Check) is calculated by the following steps:
Step 1: Load a 16-bit register (called CRC register) with FFFFH.
Step 2: Exclusive OR the first 8-bit byte of the command message with the low order byte of the 16-bit CRC register, putting the result in the CRC register.
Step 3: Shift the CRC register one bit to the right with MSB zero filling. Extract and examine the LSB.
Step 4: If the LSB of CRC register is 0, repeat step 3, else Exclusive or the CRC register with the polynomial value A001H, putting the result in the CRC register.
Step 5: Repeat step 3 and 4 until eight shifts have been performed. When this is done, a complete 8-bit byte will have been processed.
Step 6: Repeat step 2 to step 5 for the next 8-bit byte of the command message.
Continue doing this until all bytes have been processed. The final contents of the CRC register equal the CRC value.
Note: When transmitting the CRC value in the message, the upper and lower bytes of the CRC register must be swapped, i.e. the lower order byte will be transmitted.

13 Panel Cutout and Terminals Identification

Panel Cutout (units: mm)

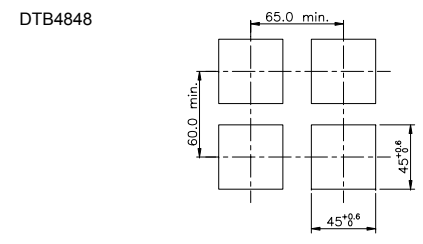
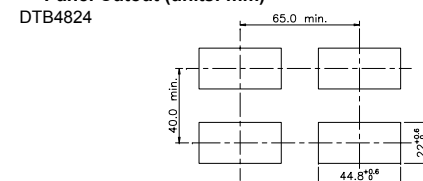

Terminals Identification

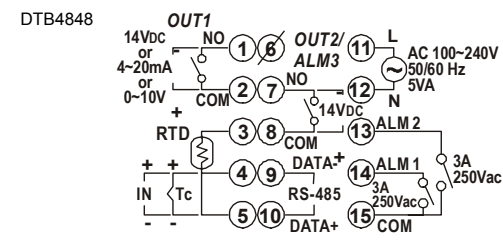
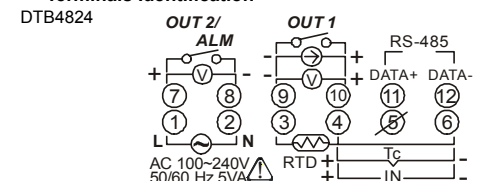

Panel Cutout (units: mm)

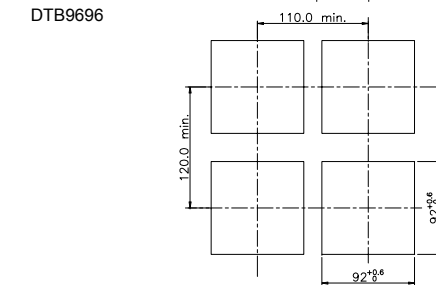
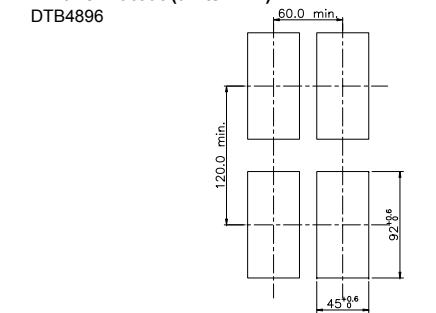

14 External Dimensions (units: mm)

DTB4824

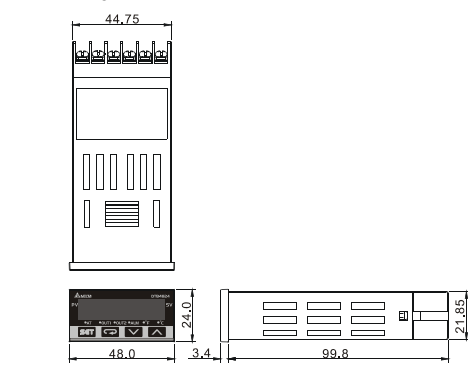

DTB4896

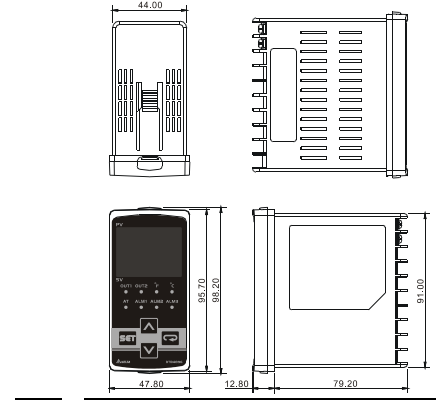

Terminals Identification

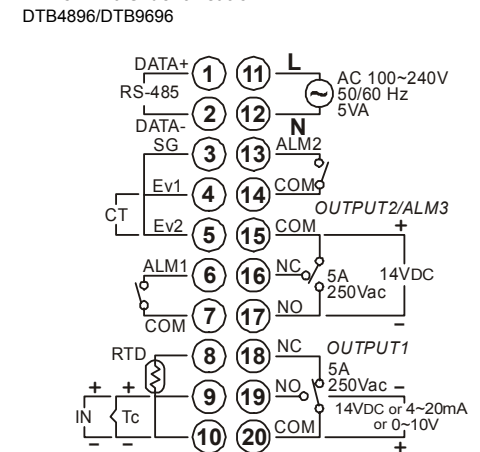

DTB4848

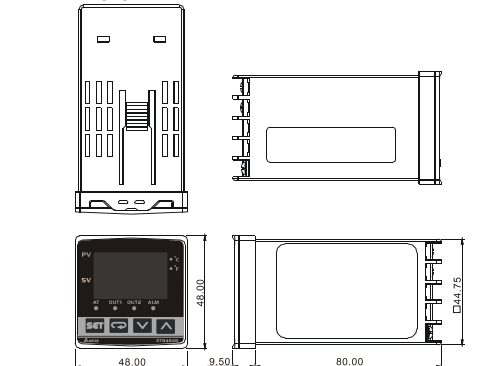

DTB9696

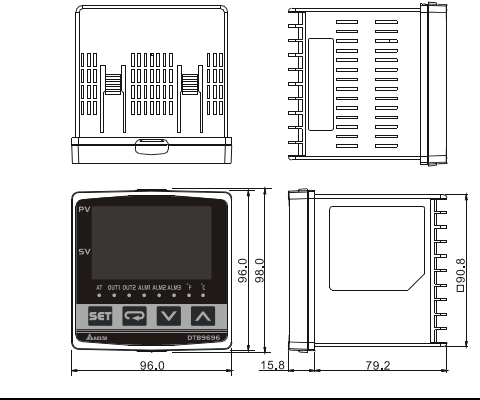

15 Mounting

Mounting Method

Step 1: Insert the controller through the panel cutout.
Step 2: Insert the mounting bracket into the mounting groove at the top and bottom of the controller.
Step 3: Push the mounting bracket forward until the bracket stops at panel wall.
Step 4: Insert and tighten screws on bracket to secure the controller in place. (The screw torque should be 0.8kgf-cm to 1.5kgf-cm)

DTB4824 Mounting Method:

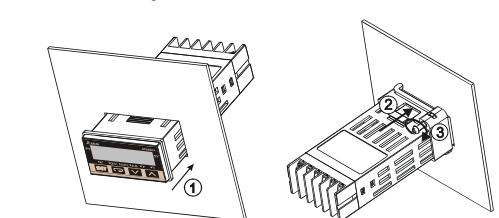

DTB4848/4896/9696 Mounting Method:

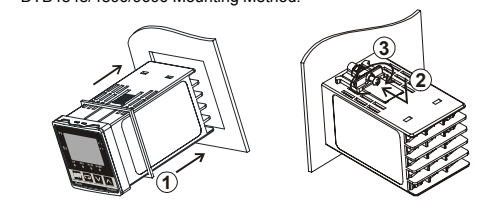

Mounting Bracket Installation

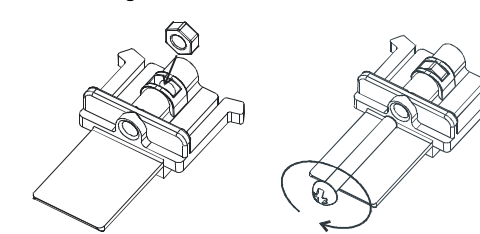

CT Wiring Method (if CT function is selected)

