

EIR208 Series Quick Start Guide

Package Contents

- EIR208 Series Industrial, Unmanaged, Ethernet Switch
- Quick Start Guide (One per shipment)
- Power Terminal Block (installed)
- Fiber Optic Dust Covers (installed on fiber optic models)

If any item is missing or damaged, contact B&B Electronics for a replacement

Front Panel

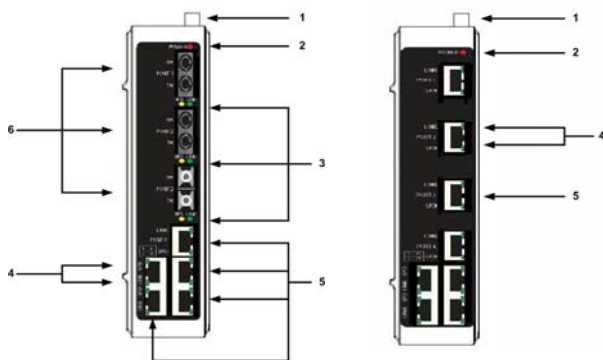

EIR208 (3 Fiber, 4 RJ45)

EIR208 (8 RJ45)

1	Power Terminal Block	2 Position, Removable
2	PWR LED	ON When Power Applied
3	Fiber Optic SPD LED	Normally OFF (100BaseFx)
3	Fiber Optic LINK LED	ON when Fiber Port Linked
4	RJ45 LINK LED	ON when RJ45 Port Linked Flashes When Data Transmitted
4	RJ45 SPD LED	ON if 100 mbps
5	RJ45 Ports	Number depends on model
6	Fiber Ports	Number and type depends on Model

DIN Rail Mounting

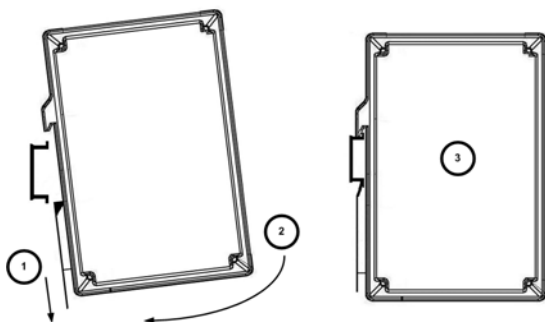

1. Slide and hold the DIN clip toward the bottom of the switch. Angle the top portion of the DIN mount over the top of DIN Rail.
2. Move the switch so that it is parallel with the DIN Rail.
3. Let go of the DIN Clip. The spring should return it to its original position.

Attach Power Leads External Supply Required



Warning: Work Safe – Equipment damage or electrical shock hazard exists. DO NOT ATTACH OR REMOVE LEADS WITH THE POWER SUPPLY ENERGIZED!

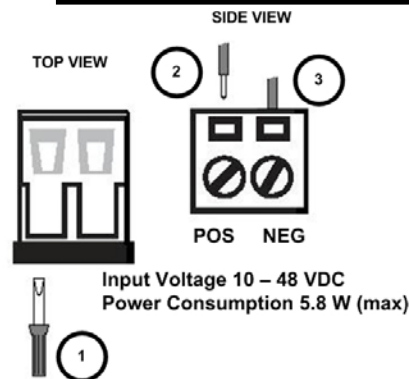

1. Loosen the screw to open the terminal block lead clamp.
2. Insert the power lead. TB will accept 12-28 AWG wire.
3. Tighten the screw to close the terminal block lead clamp. Ensure the clamp holds the lead securely. However, do not over tighten.

NOTE: For Replacement Terminal Block OrderPart #7444.

Attach RJ45 Cable

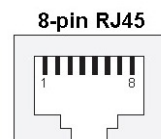

1. Auto MDI/MDI-x is supported. A straight through or cross-over cable may be used.
2. 10/100BaseT auto negotiation and full/half-duplex are supported.

MDI Cable Pinout	Pin	Signal
	1	Tx+
	2	Tx-
	3	Rx+
	6	Rx-

MDI-X Cable Pinout	Pin	Signal
	1	Rx+
	2	Rx-
	3	Tx+
	6	Tx-



International Headquarters: 707 Dayton Road PO Box 1040 Ottawa, IL 61350 USA
815-433-5100 Fax 433-5104 www.bb-elec.com orders@bb-elec.com support@bb-elec.com

European Headquarters: Westlink Commercial Park Oranmore Co. Galway Ireland
+353 91 792444 Fax +353 91 792445 www.bb-europe.com orders@bb-europe.com support@bb-europe.com

Attach Fiber Optic Cable (if equipped)



Warning: Work Safe – Fiber Optic equipped models are Class I Laser/LED devices. To avoid causing serious damage to your eyes, DO NOT STARE DIRECTLY INTO THE LIGHT.

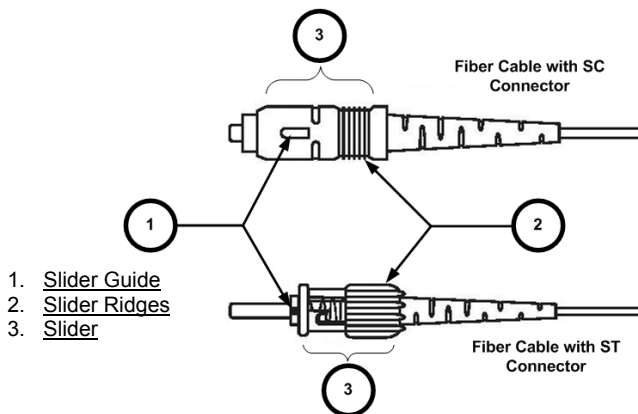

1. Slider Guide
2. Slider Ridges
3. Slider

1. Ensure your fiber optic cable is terminated with the correct connector type. EIR208 switches use SC or ST connectors.
2. Fiber optic type for each port is located on the product's side label. When connecting the cable to the switch, be sure to line up the slider guide on the cable and switch connectors.
3. Connect the fiber optic transmitter to the downstream device's receiver and vice-versa.

Fiber Optic Cable Information

Mode and Distance	Type	Wavelength
Multi-mode (2 km)	62.5/125 μ m	1310 nm
Single-mode (15 km)	9/125 μ m	1310 nm
Single-mode (40 km)	9/125 μ m	1310 nm
Single-mode (80 km)	9/125 μ m	1550 nm

	Output Power	RCVR Sensitivity
Multi-mode (2 km)	-19 to -14 dBm	\leq -32 dBm
Single-mode (15 km)	-15 to -8 dBm	\leq -32 dBm
Single-mode (40 km)	-5 to 0 dBm	\leq -34 dBm
Single-mode (80 km)	-5 to 0 dBm	\leq -34 dBm

Installation Complete

1. When the network cables are attached and power is applied, installation is complete.
2. The switch will automatically discover network devices, populate its MAC address table, and pass traffic to the appropriate ports.

Mechanical Diagram

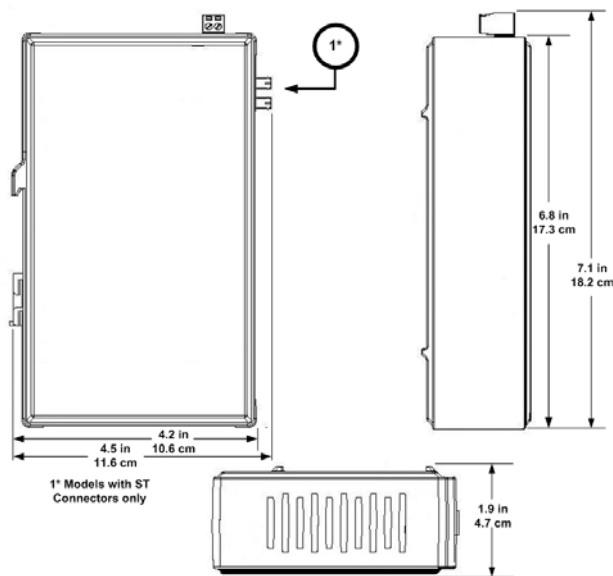

International Headquarters: 707 Dayton Road PO Box 1040 Ottawa, IL 61350 USA
 815-433-5100 Fax 433-5104 www.bb-elec.com orders@bb-elec.com support@bb-elec.com

European Headquarters: Westlink Commercial Park Oranmore Co. Galway Ireland
 +353 91 792444 Fax +353 91 792445 www.bb-europe.com orders@bb-europe.com support@bb-europe.com