

WATER RESISTANT USB 2.0 CONNECTOR SERIES ASSEMBLY INSTRUCTIONS

CONEC Industrial Circular Sealed USB Connector System consists of a **USB 2.0 Type A Plug Assembly Kit**, a **USB 2.0 Cable Strain Relief Kit**, a **USB 2.0 Type A Receptacle Kit** and a **Protective Cover Assembly**.

1. The USB 2.0 Type A Plug Assembly Kit (Bayonet Locking Style)

1.1 Introduction

The USB type A plug Assembly kit consists of a solder cup **USB 2.0 Type A Plug** and a **Plug Housing Assembly (Bayonet)**. The solder cup USB Type A plug consists of 2 portions of the metal shell and 2 portions of the insulators. See Figure 1-1 for details.

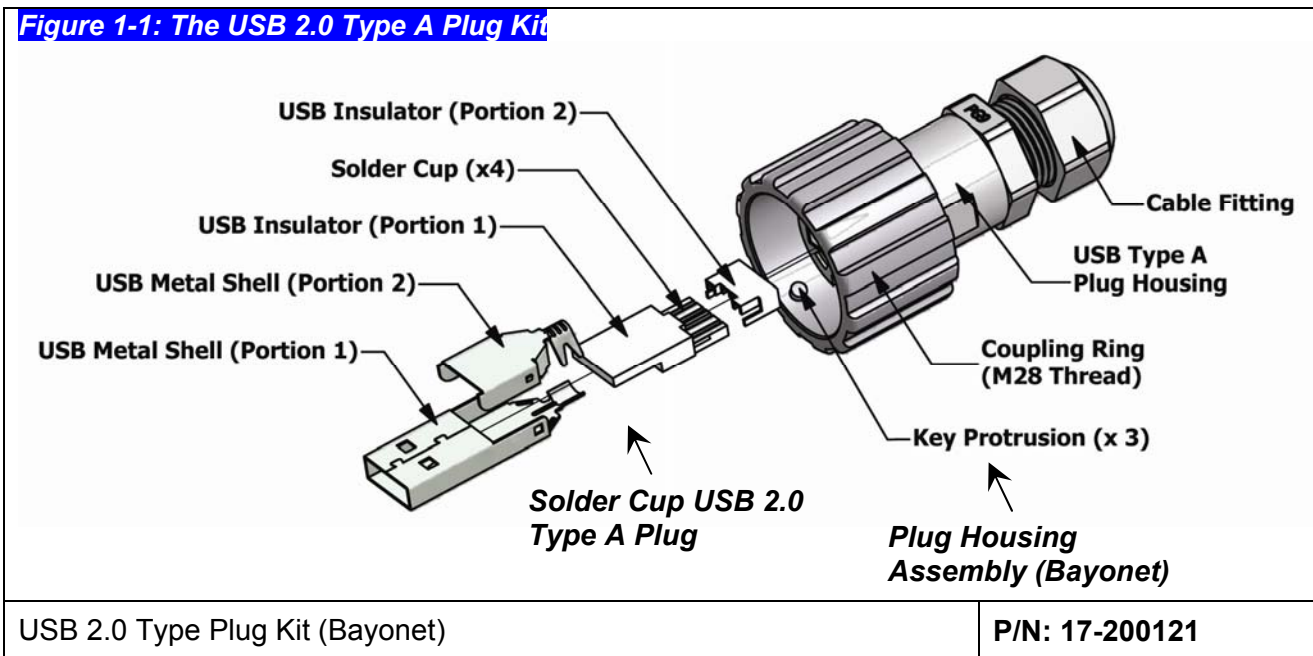

2 USB Cable Strain Relief Kit (M28 Thread)

2.1 Introduction

The RJ45 cable strain relief kit consists of a solder cup **USB 2.0 Type A Plug** and a **Plug Housing Assembly (M28 Thread)**. The solder cup USB type A plug consists of 2 portions of the metal shell and 2 portions of the insulators. See Figure 1-2 for details.

Figure 2-1: USB Cable Strain Relief Kit

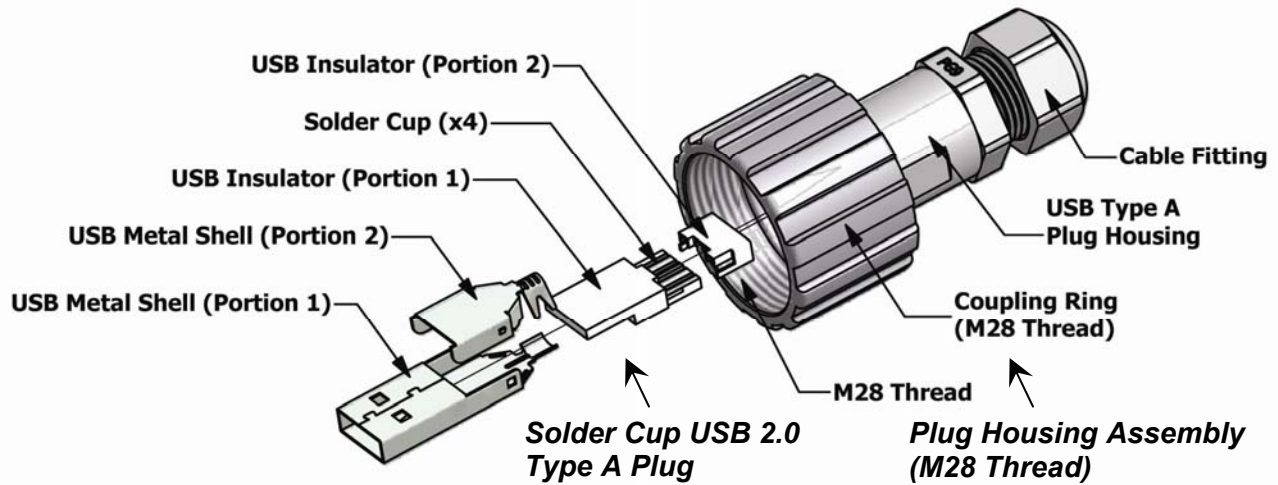

USB Cable Strain Relief Kit (M28 Thread)

P/N: 17-200151

3. USB Type A Plug (Solder Cup version) Assembly

3.1 USB Connector Termination Data

Figure 3-1 shows the pin number of the contact of the USB Type A plug and table 3-1 provides the standardized contact terminating assignment by number and electrical value of the USB type A and type B connectors

Figure 3-1: Pin Number Assignment for USB Type A Plug

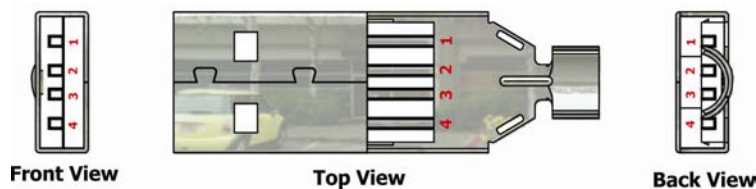
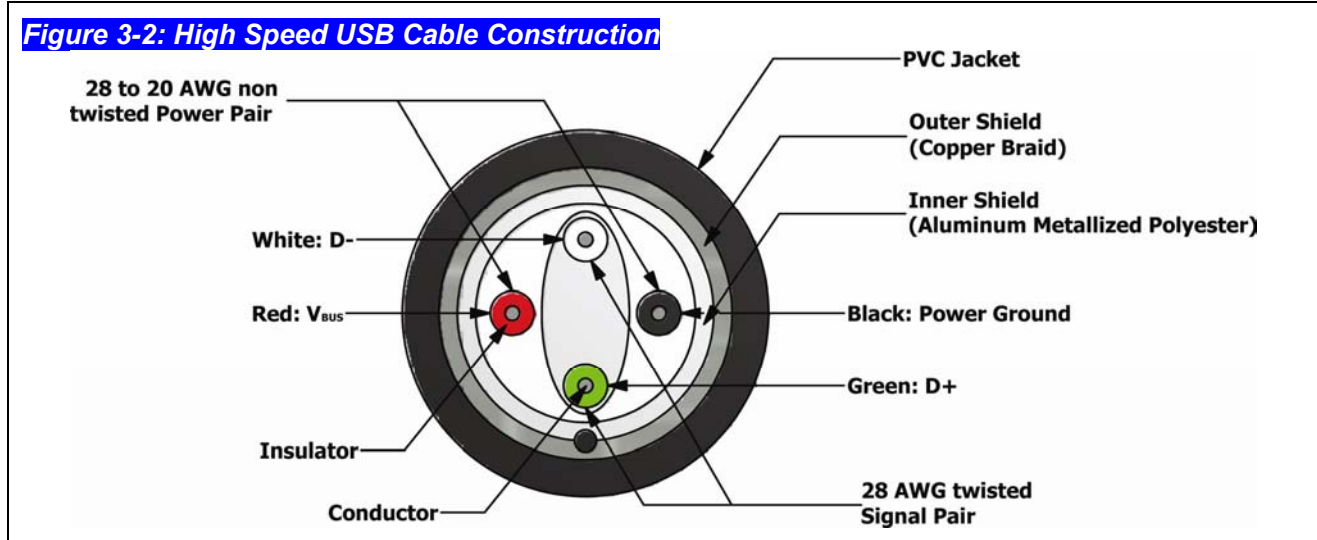

Table 3-1: USB Type A and Type B Connector Termination Assignment

Pin Number	Signal Name	Typical Wiring Assignment of USB Cable
1	V _{BUS}	Red
2	D-	White
3	D+	Green
4	GND	Black
Metal Shell	Shield	Drain Wire

3.2 High Speed USB Cable Construction

High speed USB cable consists of one 28 to 20 AWG non-twisted power pair and one 28 AWG twisted data pair with an aluminum metallized polyester inner shield, 28 AWG stranded tinned copper drain wire, copper braid outer shield, and PVC outer jacket. Figure 3-2 shows the typical high speed USB cable construction.



3.2.1 Conductor Construction

Table 3-2: Non-twisted Power Pair Conductors

American Wire Gauge	Nominal Conductor Outer Diameter	Stranded Tinned Conductors
AWG 28	0.381mm (0.015")	7 x 36
	0.406mm (0.016")	19 x 40
AWG 26	0.483mm (0.019")	7 x 34
	0.508mm (0.020")	19 x 38
AWG 24	0.610mm (0.024")	7 x 32
	0.610mm (0.024")	19 x 36
AWG 22	0.762mm (0.030")	7 x 30
	0.787mm (0.031")	19 x 34
AWG 20	0.890mm (0.035")	7 x 28
	0.931mm (0.037")	19 x 32

Table 3-3: Twisted Signal Pair Conductors

American Wire Gauge	Nominal Conductor Outer Diameter	Stranded Tinned Conductors
AWG 28	0.381mm (0.015") 0.406mm (0.016")	7 x 36 19 x 40

Table 3-4: Non Insulator Drain Wire Conductor

American Wire Gauge	Nominal Conductor Outer Diameter	Stranded Tinned Conductors
AWG 28	0.381mm (0.015") 0.406mm (0.016")	7 x 36 19 x 40

Table 3-5: Nominal USB Cable Outer Diameter

Shielded USB Cable Configuration	Nominal Cable Outer Diameter
AWG 28/AWG 28	4.06mm (0.160")
AWG 28/AWG 26	4.32mm (0.170")
AWG 28/AWG 24	4.57mm (0.180")
AWG 28/AWG 22	4.83mm (0.190")
AWG 28/AWG 20	5.21mm (0.205")

The first 3 cable configurations of above table 3-5 are recommended to be used with this solder cup USB Type A Plug.

3.3 USB Type A Plug (Solder Cup Version) Assembly

Step 1: Strip the jacket and wires of the USB cable according to the Figure 3-3.

Figure 3-3: USB Cable Preparation

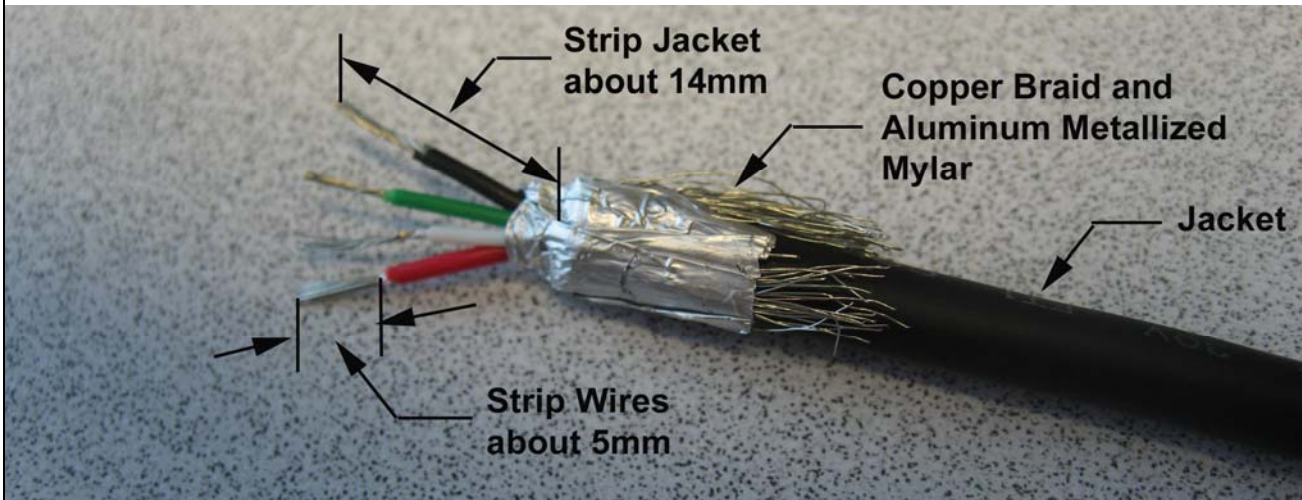

Step 2: Solder the wires of the USB cable to the solder cups of the USB plug of the insulator portion 1 according to the Figure 3-4.

Figure 3-4: Layout showing the wires Soldered to USB Plug

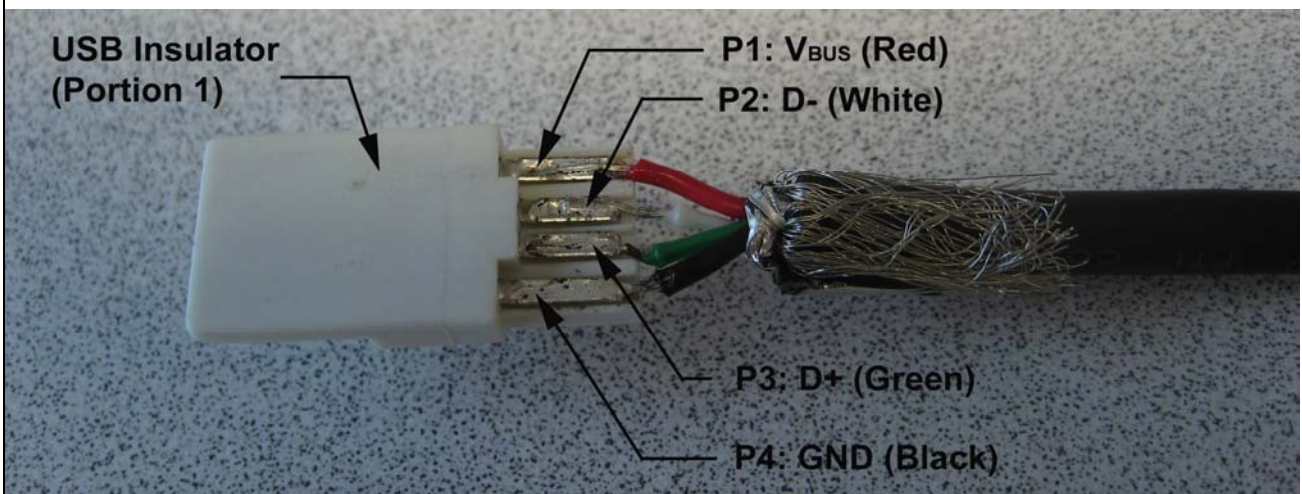

Step 3: Slide the USB insulator portion 2 against portion 1. See Figure 3-5 for details.

Figure 3-5: Assembly of the USB Insulator

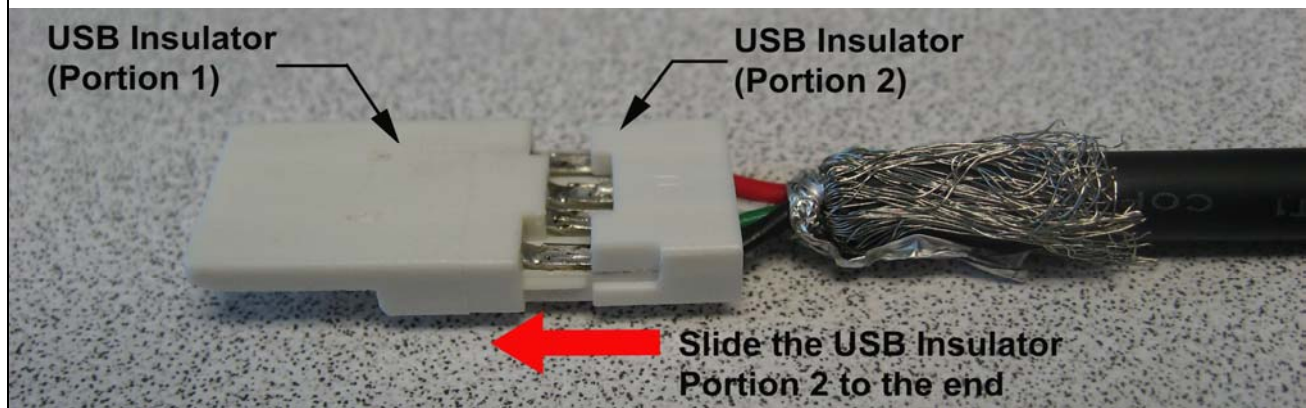

Step 4: Insert the assembled USB Insulator into the metal shell portion 1 all the way to end.

Figure 3-6: Assembly of the USB Insulator and Metal Shell Portion 1

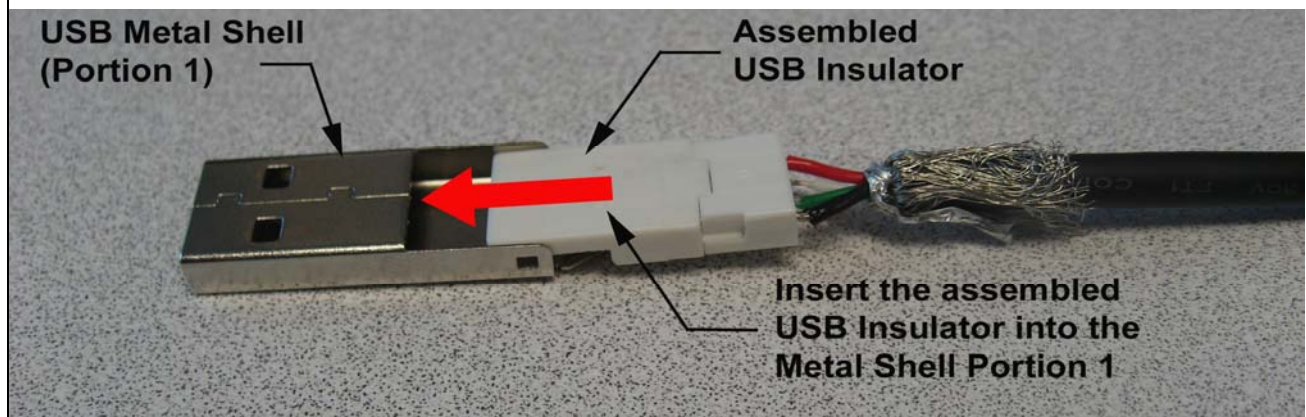

Step 5: Place the metal shell portion 2 in the proper position with the portion 1 according to Figure 3-7 and press the portion 2 straight down until both locking tabs of the portion 2 snap into the holes of the metal shell portion 1.

Figure 3-7: Assembly of the Metal Shell

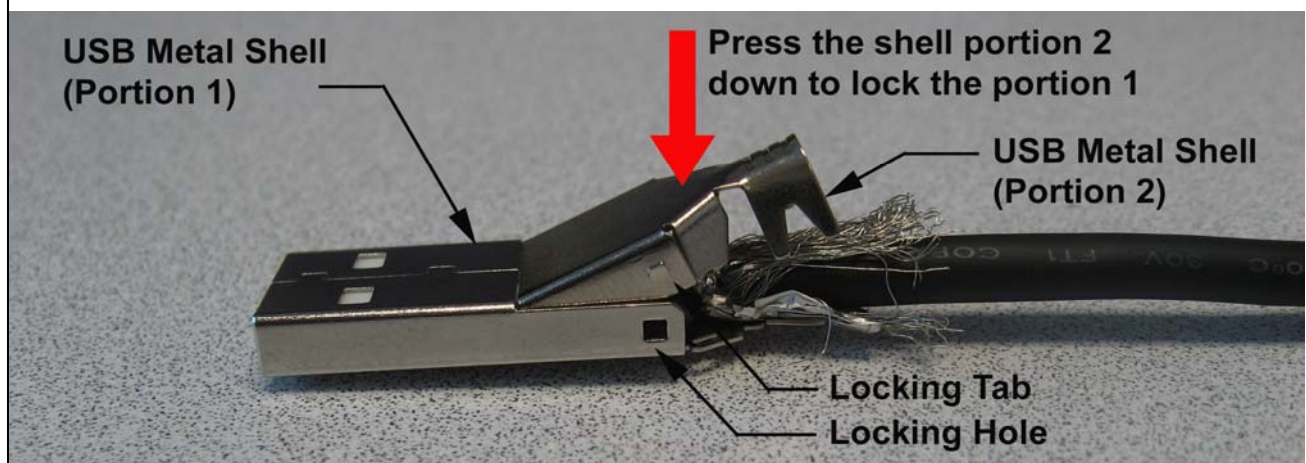

Step 6: Use pliers to tightly close the 3 grounding fingers of the metal shell portion 2 with portion 1 together, and cut the rest of copper braid and aluminum metallized mylar.

Figure 3-8: Terminate the USB Metal Shells

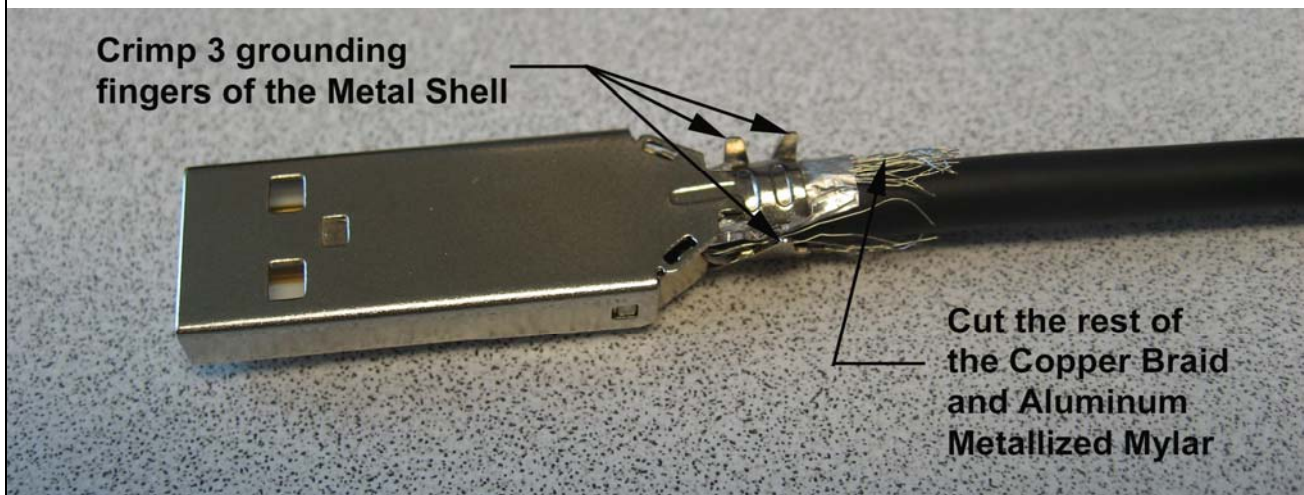

4 Assembly of the USB Type A Plug Housing

Step 1: Position the USB plug top side towards the mating slot of the USB plug housing or position the USB bottom side towards the CONEC logo of the USB plug housing shown in Figure 4-1.

Figure 4-1: Assembly of the USB Type A Plug Housing (Step 1)

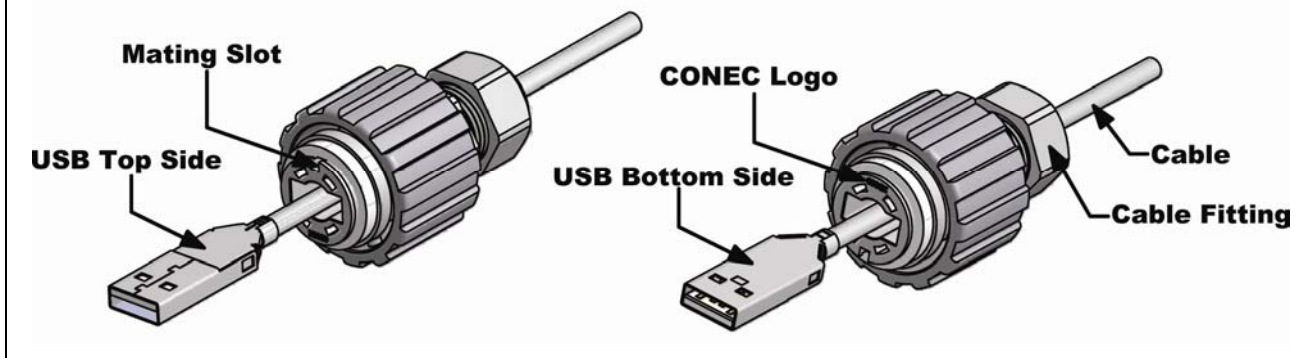

Step 2: Gently pull the cable until the plug is fully seated. Hold the plug in position and rotate the cable fitting until tightened to a torque of 2.27 Nm (20 lb-in). See Figure 4-2.

Figure 4-2: Assembly of the USB Type A Plug Housing (Step 2)

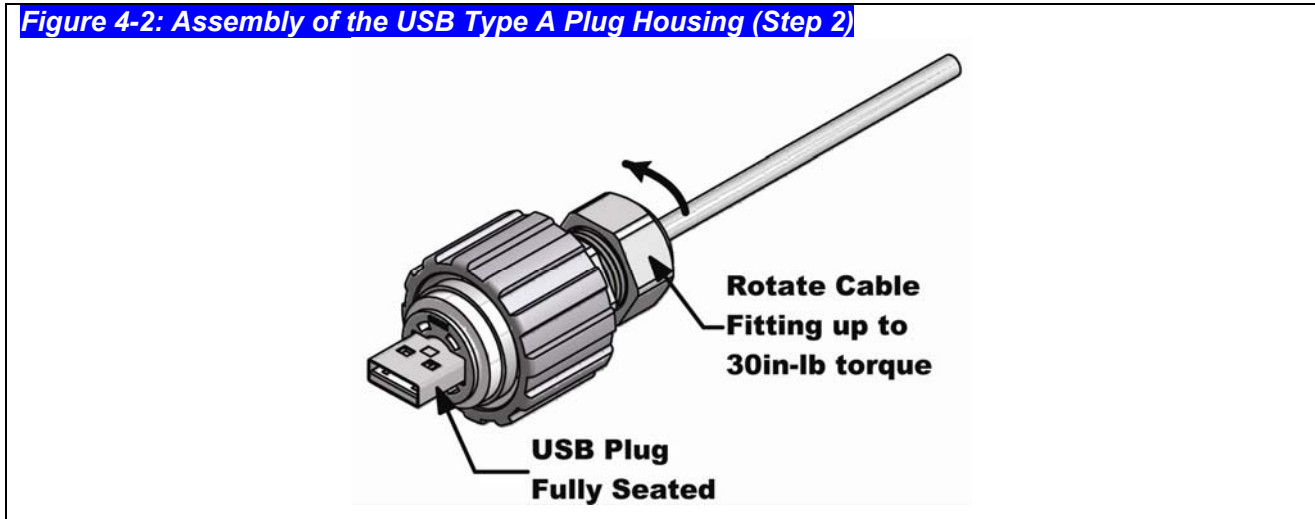

5. The Receptacle Assembly Kit

5.1 The Cat. 5e RJ45 Inline Coupler Receptacle Assembly Kit

This Receptacle Assembly kit consists of a *RJ45 Inline Coupler Receptacle Assembly*, a *Panel Gasket* and a *Panel Nut*. There are plastic and metal versions available for the *Receptacle Housing*. See Figure 5-1 for details.

Figure 5-1: USB 2.0 Receptacle Assembly Kit

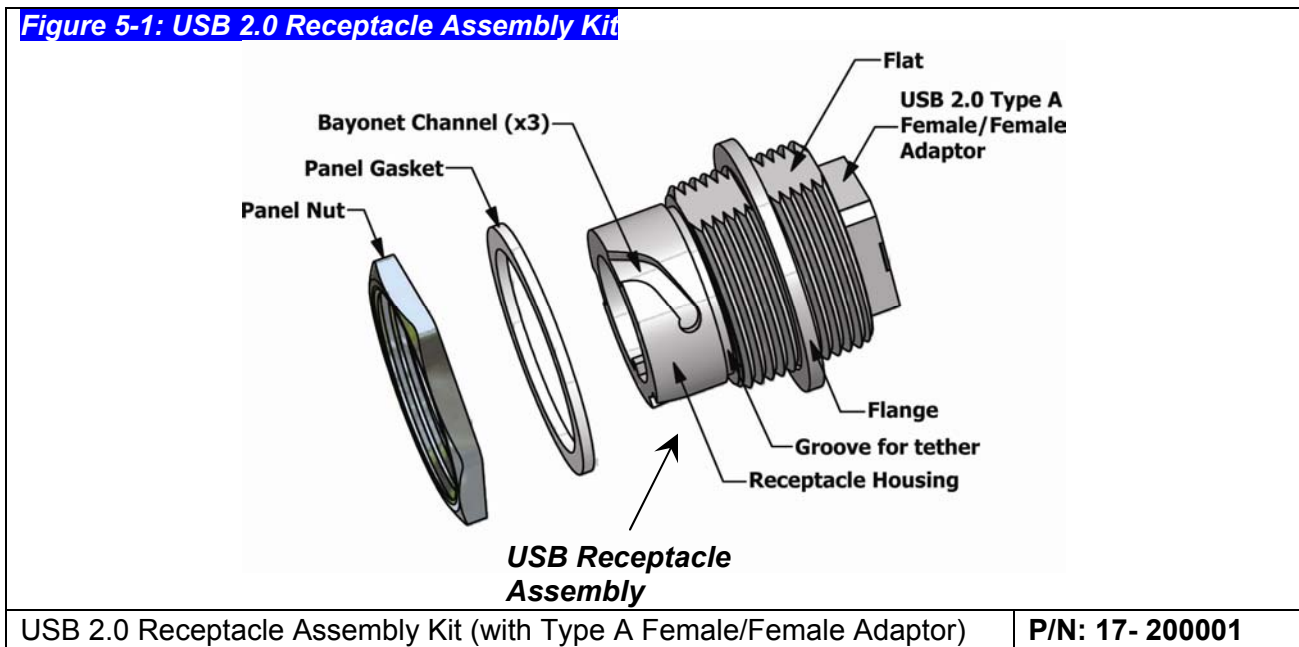

6 Protective Cover Assembly

6.1 Introduction

The **Protective Cover Assembly** consists of a *Cover Coupling Ring*, a *Cover Gasket* and a *Tether*. See Figure 6-1 for details.

Figure 6-1: Protective Cover Assembly

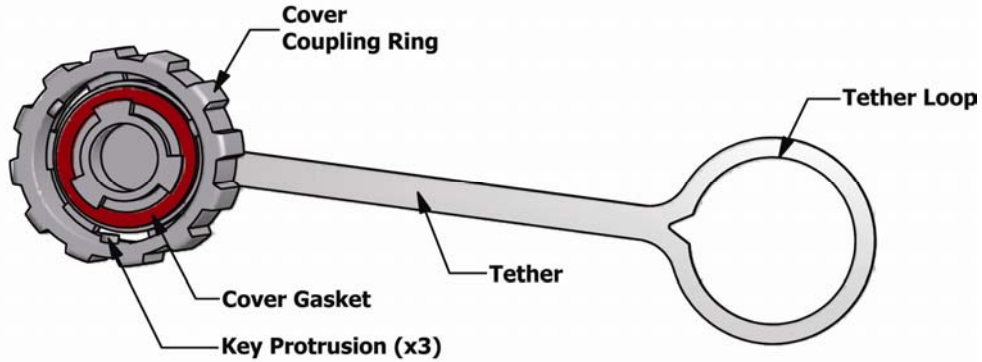

USB Protective Cover Assembly

P/N: 17-10002

7. The Receptacle + Protective Cover Assembly Kit

7.1 Introduction

This kit consists of a **Receptacle Assembly** and a **Protective Cover Assembly**. See Figure 7-1 for details.

Figure 7-1: USB Receptacle + Protective Cover Assembly Kit

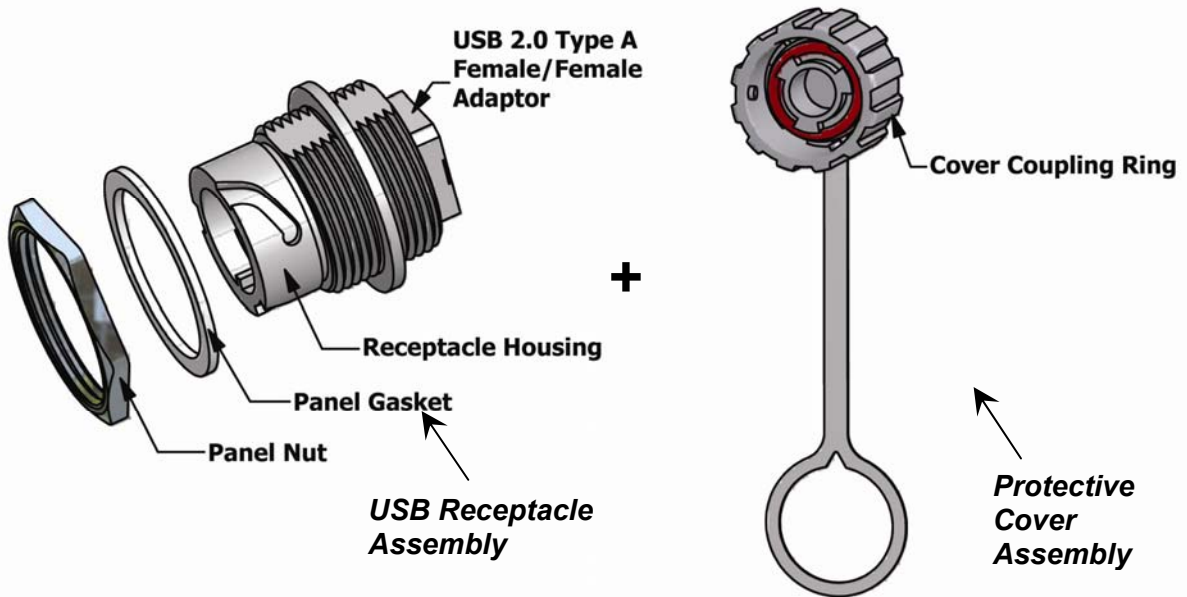

USB Receptacle + Protective Cover Assembly Kit

P/N: 17-200161

8 Panel Cutout

8.1 Introduction

A panel thickness of up to 3.20 mm may be used. The recommended panel cutout dimension is shown on Figure 8-1.

Figure 8-1: Recommended Panel Cutout

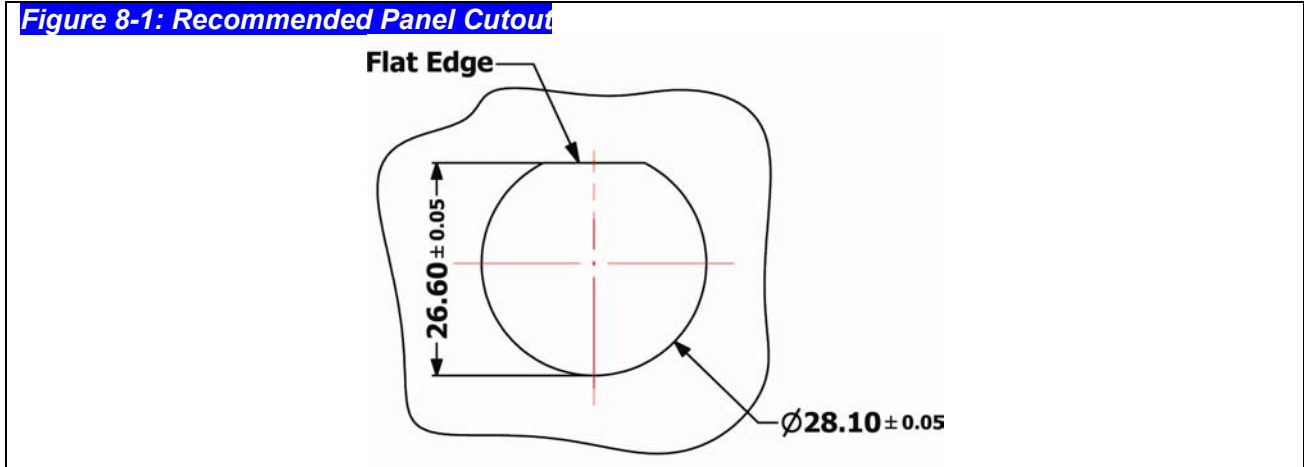

8.2 Panel Mounting

The receptacle is designed for front or rear panel mounting as shown in Figure 8-2 and Figure 8-3. The panel nut (M28 x 1.5) should be tightened to a torque of 2.27 Nm (20 lb-in).

The **Protective Cover** must be installed onto the **Receptacle Assembly** and cover the receptacle immediately for insuring the IP67 sealing performance once the **Plug Assembly** is removed from the receptacle.

Figure 8-2: The Receptacle Panel Front Mounting

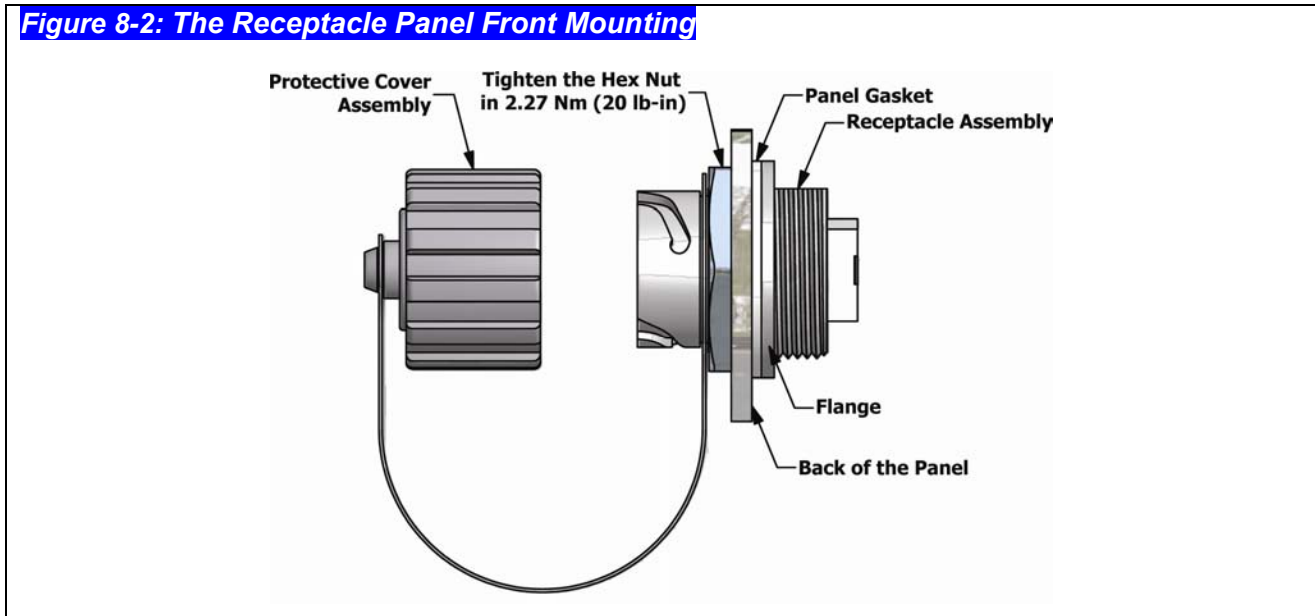
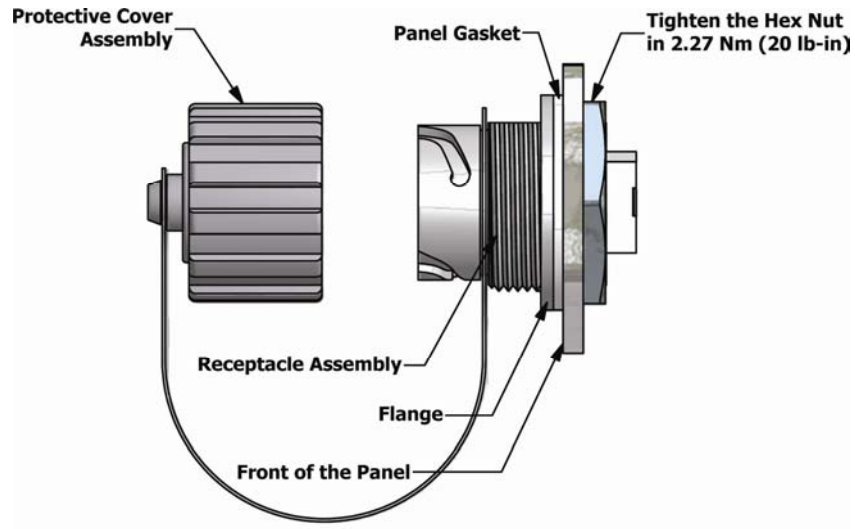

Figure 8-3: The Receptacle Panel Rear Mounting



9 Connector Engagement

9.1 USB Plug and Receptacle Engagement (Bayonet Locking Style)

Gently insert the USB plug (Bayonet) into the USB receptacle, align the 3 keys of the bayonet coupling ring with 3 bayonet channels of the USB receptacle and rotate the bayonet coupling ring until the 3 keys “click” into the bayonet channels. See Figure 9-1 for details.

Figure 9-1: USB Plug and Receptacle Engagement (Bayonet Locking Style)

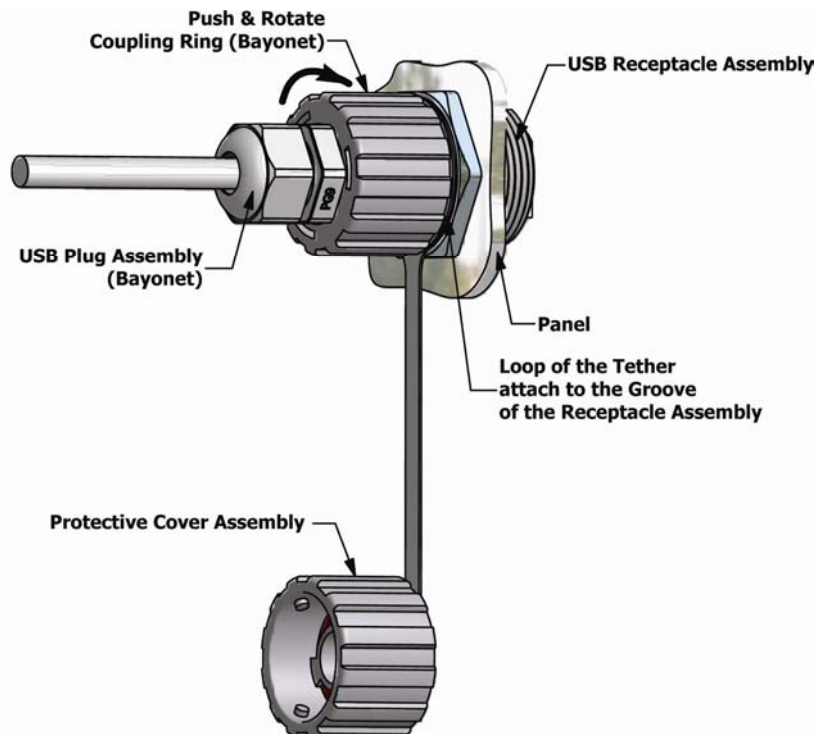

9.2 USB Plug and Receptacle Engagement (M28 Thread)

Gently insert the assembled plug (Thread) into the Jack adaptor of the USB receptacle then fully thread the M28 coupling ring. See Figure 9-2 for more details.

Figure 9-2: USB Plug and Receptacle Engagement (M28 Thread)

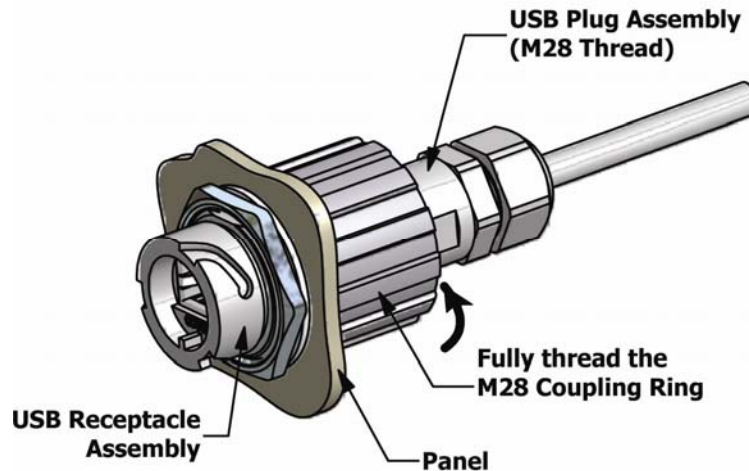

9.3 Protective Cover Engagement

The protective cover must be installed onto the **USB Receptacle Assembly** and engaged with the receptacle immediately for insuring IP67 sealing performance whenever the **USB Plug Assembly (Bayonet)** is removed from the **USB Receptacle Assembly**.

The tether of the protective cover should be attached to the **USB Receptacle Assembly** if it is to be used. Place the loop of the tether in the groove (located between the end of the bayonet channels and the hex nut) of the **USB Receptacle Assembly**. See Figure 9-3.

Figure 9-3: Cover Engagement (Bayonet Locking Style)

