

Space-saving Signal Conditioners M3-UNIT Series

FREQUENCY TRANSMITTER
(field- and PC-configurable)

MODEL **M3LPA**

MODEL & SUFFIX CODE SELECTION

M3LPA-□/□□

MODEL _____

INPUT SELECTION

- Open Collector
- Mechanical Contact
- Voltage Pulse
- Two-wire Current Pulse
- RS-422 Line Driver

EXCITATION SELECTION

- 4V DC / 20mA
- 8V DC / 20mA
- 12V DC / 20mA

OUTPUT SELECTION

- ◆DC Current: Usable range 0 – 20mA; min. span 1mA
- ◆DC Voltage
 - Narrow Spans: Usable range ±2.5V; min. span 250mV
 - Wide Spans: Usable range ±10V; min. span 1V

POWER INPUT

- M2 : 100 – 240V AC
- R4 : 10 – 32V DC

CONFIGURATION OPTIONS

- A : PC and field configurable
- B : Field configurable

OPTIONS

- /UL : UL approval
(selectable only with DC power input code R4)

ORDERING INFORMATION

Specify code number. Orders will be shipped at default factory settings as shown in the table below.
Ordering example:

- Code number (e.g. M3LPA-R4/A)

ITEM	FACTORY SETTING
Input type	Open collector
Frequency range	0 – 100 kHz
Sensor excitation	12V DC / 20mA
Output range	4 – 20mA
Threshold	2V

RELATED PRODUCTS

- PC configurator software (model: M3CON)
Downloadable at M-System's web site:
<http://www.m-system.co.jp>
- PC configurator cable (model: MCN-CON)

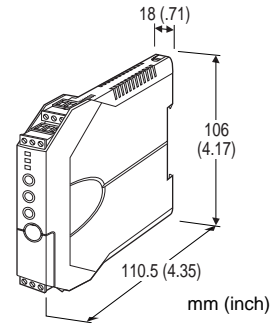

Functions & Features

- Converts the output from a pulse-type transducer into a standard process signal
- Sensor excitation
- Easy 'One-Step Cal' calibration using the front three control buttons without needing a PC; PC software is also usable.
- Both input and output type and range are configurable
- UL approval

Typical Applications

- Positive displacement flowmeters, turbine flowmeters and vortex flowmeters
- Measuring rotation speed of a machine generating dry contact signals

GENERAL SPECIFICATIONS

- Connection:** Removable terminal block
- Housing material:** Flame-resistant resin (grey)
- Isolation:** Input to output to power
- Overrange output:** Approx. -15 – +115%
- Fine zero and span adjustments:** ±15% via the front control buttons

Configuration

'One-Step Cal' calibration: With I/O type and the full-scale range configured via the internal DIP switches, precise 0% and 100% ranges are calibrated via the front control buttons with a help of LED.

PC configurator (model: M3CON): Via Windows PC connected to the front jack.

Programmable features include:

- I/O type and range, threshold
- Zero and span adjustments

Status indicator LED: Tri-color (green/amber/red) LED; Flashing patterns indicate operation status of the transmitter.

INPUT

Measurable frequencies: Minimum span 10% of the frequency range selected in Table 3.
See each input type for the maximum span.
Time constant is set to 50 msec. with the 'large' noise filter setting and to 10 msec. with the 'small' noise filter setting (Table 9).

Pulse width time requirement: Min. 5 μ sec.,
max. 10 sec.

OPEN COLLECTOR

Maximum frequency: 0 – 100 kHz

Input amplitude: Min. 4V, max. 12V

Sensing voltage/current: Approx. 12V, 8V or 4V DC
@1mA

Detecting levels: $\leq 200\Omega$ for ON; $\geq 200k\Omega$ for OFF

MECHANICAL CONTACT

Maximum frequency: 0 – 10 Hz

Input amplitude: Min. 4V, max. 12V

Sensing voltage/current: Approx. 12V, 8V or 4V DC
@1mA

Detecting levels: $\leq 200\Omega$ for ON; $\geq 200k\Omega$ for OFF

VOLTAGE PULSE

Maximum frequency: 0 – 100 kHz

Waveform: Square or sine

Input impedance: 10k Ω minimum

Input amplitude: Min. 0.1V p-p, max. 100V p-p*

Max. voltage between input terminals: 100V*

Detecting levels: -2 – +4V

*30V rms, 42.4V peak or 60V DC for UL approval

TWO-WIRE CURRENT PULSE

Maximum frequency: 0 – 100 kHz

Input resistance: Receiving resistor 100 Ω

Input range: 0 – 25mA

Input amplitude: Min. 4mA, max. 20mA

Detecting levels: -2 – +4V

RS-422 LINE DRIVER PULSE

Maximum frequency: 0 – 100 kHz

Receiver: Conforms to RS-422

OUTPUT**DC CURRENT**

Maximum range: 0 – 20mA DC

Minimum span: 1mA

Conformance range: 0 – 24mA DC

Offset: Lower range can be any specific value within the output range provided that the minimum span is maintained.

Load resistance: Output drive 12V maximum
(Range) 0 – 20mA : 600 Ω maximum

DC VOLTAGE**Narrow Spans (mV)**

Maximum range: -2.5 – +2.5V DC

Minimum span: 250mV

Conformance range: -3 – +3V DC

Wide Spans (V)

Maximum range: -10 – +10V DC

Minimum span: 1V

Conformance range: -11.5 – +11.5V DC

Offset: Lower range can be any specific value within the output range provided that the minimum span is maintained.

Load resistance: Output drive 1mA maximum

(Range) 0 – 10V : 10k (Ω minimum)

-10 – 0V : 10k

0 – 2.5V : 2.5k

-2.5 – 0V : 2.5k

INSTALLATION**Power input**

AC: Operational voltage range 85 – 264V AC;
47 – 66 Hz; approx. 5VA at 100V
approx. 7VA at 200V
approx. 8VA at 264V

DC: Operational voltage range 9 – 36V DC;
approx. 3W; ripple 10% p-p max.

Operating temperature: -25 to +65°C (-13 to +149°F)
Max. 55°C (131°F) for UL approval

Operating humidity: 0 to 95% RH (non-condensing)

Mounting: DIN rail

Dimensions: W18xH106xD110.5 mm
(0.71"x4.17"x4.35")

Weight: 100 g (0.22 lbs)

PERFORMANCE

Accuracy: Input accuracy + output accuracy

Input accuracy: $\pm 0.03\%$ of input range (Table 3)

Output accuracy: $\pm 0.03\%$ of output range (Table 10/11)

The input accuracy is inversely proportional to the input span; while the output accuracy is likewise inversely proportional to the output span.

Temp. coefficient: $\pm 0.015\%/^{\circ}\text{C}$ ($\pm 0.008\%/^{\circ}\text{F}$)

at -5 to +55°C (23 to 131°F) of I/O range

Response time: $T_s + T_d$

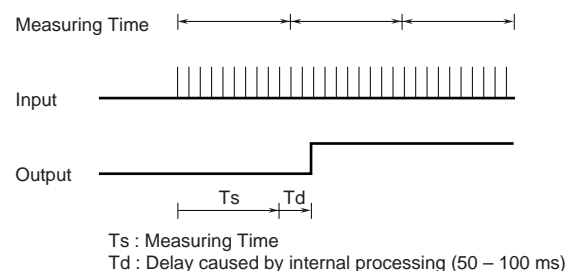

Line voltage effect: $\pm 0.1\%$ over voltage range

Insulation resistance: $\geq 100M\Omega$ with 500V DC

Dielectric strength: 1500V AC @1 minute

(input to output to power to ground)

STANDARDS & APPROVALS

CE conformity: EMC Directive (89/336/EEC)

EMI EN61000-6-4

EMS EN61000-6-2

Low Voltage Directive (73/23/EEC)

EN61010-1

Installation category II

Pollution degree 2

Max. operating voltage 300V

Input or output to power – Reinforced insulation

Input to output – Basic insulation

Approval: UL/C-UL general safety requirements
(UL 61010-1, CAN/CSA-C22.2 No.1010-1)

SCHEMATIC CIRCUITRY & CONNECTION DIAGRAM

DC POWERED TYPE

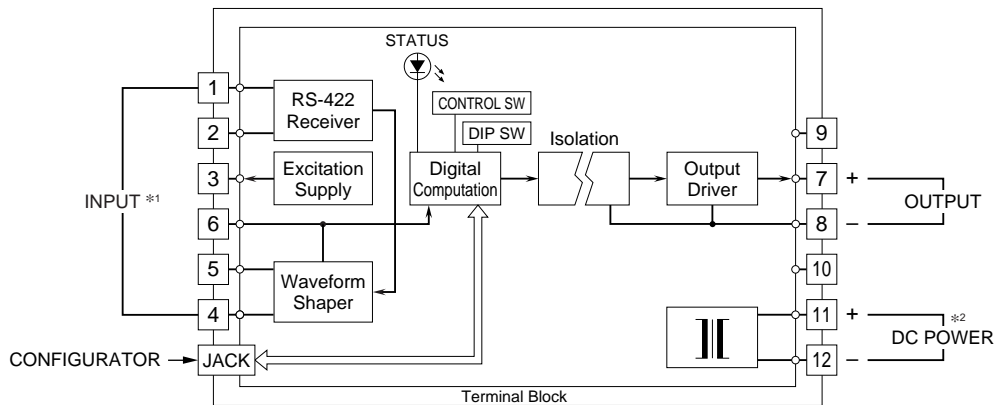

AC POWERED TYPE

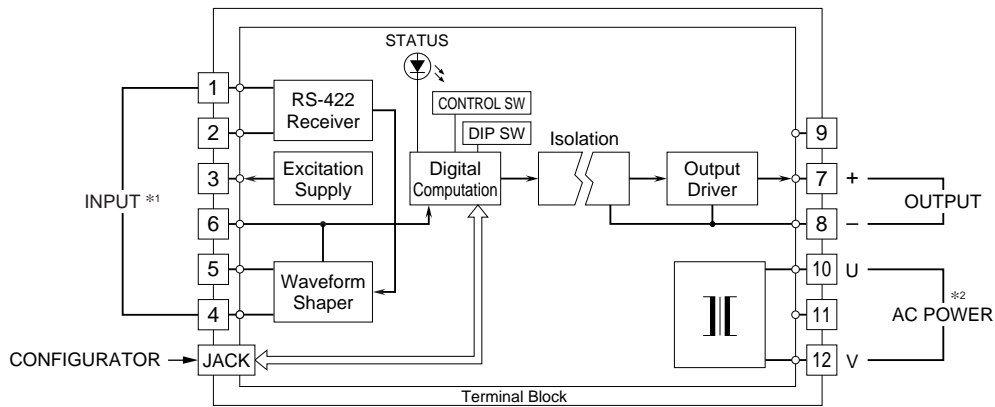

*2. Be aware that the AC power and DC power connect to different terminals.

*1. Input Connection Examples

Open Collector

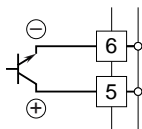

Voltage Pulse

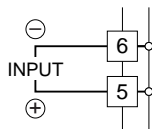

Two-wire Current Pulse

Built-in Excitation

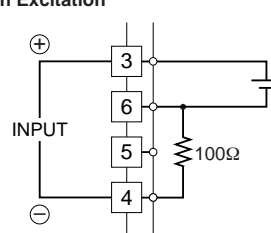

Excitation Supply

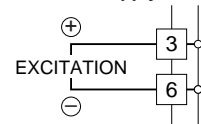

Mechanical Contact

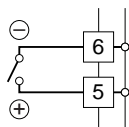

RS-422 Line Driver Pulse

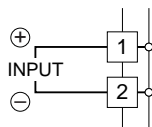

External DC Supply

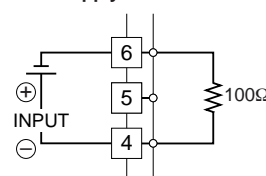

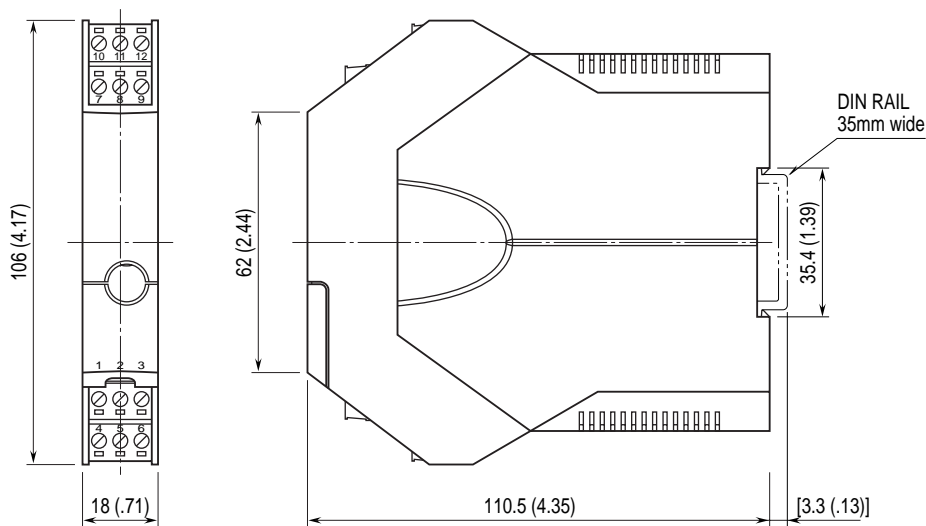
EXTERNAL DIMENSIONS & TERMINAL ASSIGNMENTS mm (inch)

•When mounting, no extra space is needed between units.

ONE-STEP-CAL CALIBRATION**CONFIGURATION MODES & DIP SW**

When you program the transmitter module, two configuration modes are available: Field Configuration using DIP SW / control buttons, and PC Software. (Option B type is for the field configuration only.)

The internal DIP switches are used to configure input and output type. Once the module is configured, precise ranges are set up with the front control buttons using a simulator connected to the input terminals and a multimeter connected to the output terminals as a reference.

INPUT & OUTPUT RANGING

For example, suppose that the DIP switches are configured for the voltage pulse (0 – 100kHz full-range). Turn the power supply to the transmitter on and press MODE button to enter to the Input Calibration Mode. Apply the desired minimum (e.g. 0 Hz) and maximum (e.g. 1 kHz) input levels and push the DOWN (zero) and UP (span) respectively to set the input range to 0 – 1 kHz.

Then the output range can be calibrated in a similar manner after moving to the Output Calibration Mode by pressing MODE button again. Increase or decrease the simulated input until the output meter shows the desired levels and push the DOWN (zero) and UP (span) respectively for the minimum (e.g. 4mA) and maximum (e.g. 20mA) levels.

The front LEDs' colors and flashing patterns help you to easily identify the transmitter's status and confirm the setup actions in each step of Calibration Modes. See detailed explanation in "Calibration Flow Chart."

The calibrated input and output ranges are stored in the internal memory. The module reads the DIP-switch-calibrated configuration only once after the power supply is turned on. Set the switches with the power supply removed.

FINE ZERO & SPAN ADJUSTMENTS

After the transmitter is installed and operational, fine zero and span tuning can be also performed using the front control buttons. Both zero and span are adjustable within $\pm 15\%$.

PC SOFTWARE CONFIGURATION

When you need to apply the same setting to multiple transmitters, downloading one setting from the PC is convenient. The PC Configurator Software (model: M3CON) is available separately.

Turn the transmitter to PC Configuration Mode (See Table 1) and all programmable features can be set up on a PC regardless of other DIP SW setting except for the following: the output type must be selected with the DIP SW1-1 through SW1-4 (See Table 11), and the pulse sensing type and noise filter must be selected with the DIP SW4-1 through SW4-3 (See Tables 8 and 9).

For detailed information on the PC configuration, refer to the M3CON instruction manual.

EXTERNAL & INTERNAL VIEWS

FRONT VIEW

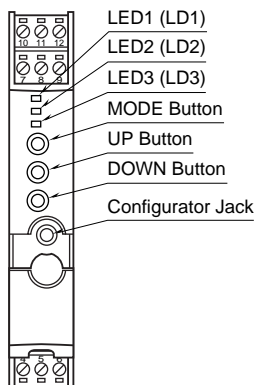

SIDE VIEW

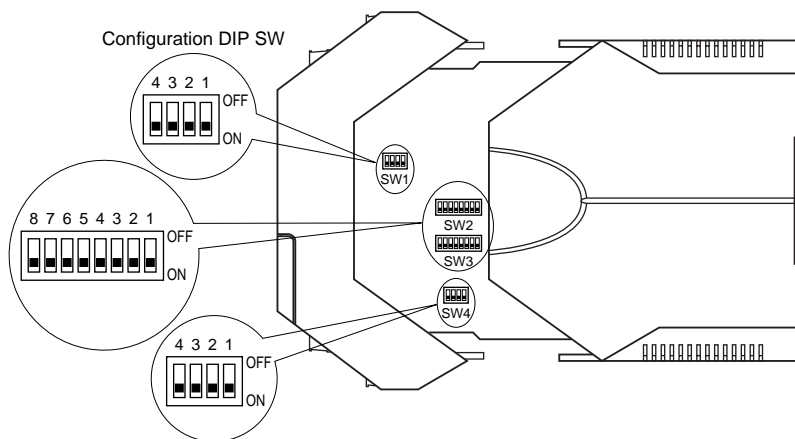

DIP SWITCH SETTINGS

CONFIGURATION MODE (SW3)

Table 1

MODE	SW3-8	
DIP SW	OFF	Configuration mode can be confirmed with the front LED.
PC	ON	

INPUT TYPE (SW2)

Table 2

INPUT	SW2-2	SW2-1
Open Collector	OFF	OFF
Mechanical Contact	OFF	OFF
Voltage Pulse	ON	OFF
Two-wire Current Pulse	OFF	ON
RS-422 Line Driver Pulse	ON	ON

FREQUENCY RANGE (SW2)

Table 3

FREQUENCY	SW2-5	SW2-4	SW2-3
0 – 10 Hz	ON	OFF	OFF
0 – 100 Hz	OFF	ON	OFF
0 – 1k Hz	ON	ON	OFF
0 – 10 kHz	OFF	OFF	ON
0 – 100 kHz	ON	OFF	ON

PULSE AMPLITUDE (SW2)

Table 4

AMPLITUDE	MAXIMUM VOLTAGE	SW2-8	SW2-7	SW2-6
50 – 100V p-p	100V *1	OFF	OFF	OFF
25 – 50V p-p	50V	ON	OFF	OFF
10 – 25V p-p	25V	OFF	ON	OFF
5 – 10V p-p	10V	ON	ON	OFF
1 – 5V p-p	5V	OFF	OFF	ON
0.5 – 1V p-p	1V	ON	OFF	ON
0.1 – 0.5V p-p	0.5V *2	OFF	ON	ON

*1. Max. 30V rms, 42.4V peak or 60V DC for UL approval.

*2. Max. input frequency limited to 50 kHz.

CUTOUT (SW3)

Table 5

CUTOUT	SW3-7
With (0.1% fixed)	ON
Without	OFF

POLARITY (SW3)

Table 6

POLARITY	SW3-6
Bipolar	OFF
Unipolar	ON

EXCITATION SUPPLY (SW3)

Table 7

EXCITATION	SW3-5	SW3-4
4V	ON	OFF
8V	OFF	ON
12V	ON	ON

PULSE SENSING (SW4) *3

Table 8

SENSING	SW4-3
Capacitor Coupled	OFF
DC Coupled	ON

NOISE FILTER (SW4) *3

Table 9

FILTER	SW4-2	SW4-1
Large	ON	OFF
Small	OFF	ON
Without	OFF	OFF

OUTPUT TYPE (SW3 & 1)

Table 10

OUTPUT	SW3-3	SW3-2	SW3-1	SW1-4	SW1-3	SW1-2	SW1-1
0 – 20mA	OFF	ON	ON	OFF	ON	OFF	OFF
-2.5 – +2.5V	ON	OFF	OFF	ON	OFF	OFF	ON
-10 – +10V	OFF	OFF	OFF	ON	OFF	ON	OFF

OUTPUT TYPE / PC CONFIG (SW1) *3

Table 11

OUTPUT	SW1-4	SW1-3	SW1-2	SW1-1
0 – 20mA	OFF	ON	OFF	OFF
-2.5 – +2.5V	ON	OFF	OFF	ON
-10 – +10V	ON	OFF	ON	OFF

*3. DIP SW setting is required for PC configuration type.

CALIBRATION FLOW CHART

