

# *Industio* **CP-114 Series User's Manual**

**3 in 1 RS-232/422/485 Industrial Serial Board for PCI Bus**

**Oct. 2001 (2nd Edition)**

The content of this manual is also available at Moxa Web Site.



**Moxa Technologies Co., Ltd.**

Tel: +866-2-8919-1230

Fax: +886-2-8919-1231

[www.moxa.com](http://www.moxa.com)

[support@moxa.com.tw](mailto:support@moxa.com.tw)

# *Industio* CP-114 Series User's Manual

The product described in this manual is furnished under a license agreement and may be used only in accordance with the terms of the agreements.

## **Copyright Notice**

Copyright ©2000, Moxa Technologies Co., Ltd.  
All rights reserved.  
Reproduction in any form without permission is prohibited.

## **Trademarks**

MOXA is a registered trademark of Moxa Technologies Co., Ltd.  
All other trademarks or registered marks in this manual belong to their respective manufacturers.

## **Disclaimer**

Information in this document is subject to change without notice and does not represent a commitment on the part of Moxa.

Moxa provides this document "as is", without warranty of any kind, either expressed or implied, including, but not limited to, the particular purpose. Moxa may make improvements and/or changes in this manual or in the product(s) and/or the program(s) described in this manual at any time.

Information provided in this manual is intended to be accurate and reliable. However, Moxa Technologies assumes no responsibility for its use, or for any infringements of rights of the fourth parties which may result from its use.

This product could include technical or typographical errors. Changes are periodically made to the information herein; these changes may be incorporated in new editions of the publication.

## **MOXA Internet Services**

Customer's satisfaction is always our number one concern. To ensure that customers get the full benefit of our services, Moxa Internet Services have been built for technical support, product inquiry, new driver update, user's manual update, etc.

The followings are the services we provide.

E-mail for technical support

address: *support@moxa.com.tw*

FTP site for free driver update

address: *ftp.moxa.com*

or

*ftp.moxa.com.tw*

user ID: *ftp*

password: *your\_email\_address*

World Wide Web (WWW) Site for product info

address: *www.moxa.com*

or

*www.moxa.com.tw*

# About This Manual

This manual is composed of six chapters and one appendix. This manual is written for installer, system administrator and software programmer.

If you are a first-time installer and system administrator, we recommend you to go through the whole manual except Chapter 4.

If you are a software programmer, you may refer to chapter 4, "Serial Programming Tools".

If you need cable wiring information, please see chapter 5, "Connection Cable and Cable Wiring".

If you encounter any problem during installation, please refer to chapter 6, "Troubleshooting".

## **Chapter 1 Introduction**

Overview and features for the *Industio* CP-114 Series are described. Also check list and overall installation guide.

## **Chapter 2 Hardware Installation**

Hardware installation for the *Industio* CP-114 Series is detailed.

## **Chapter 3 Software Installation**

Software installation, configuration, driver loading/unloading, driver upgrade and removal for various operating systems: Windows NT, Windows 95/98 and DOS.

## **Chapter 4 Serial Programming Tools**

Roughly describing the programming tools for various O.S. platforms, including *PComm* under Windows NT and Windows 95/98, and API-232 under DOS. Also RS-485 programming issue is covered.

## **Chapter 5 Connection Cable and Cable Wiring**

Describing the RS-232 and RS-422/485 cable wiring.

## **Chapter 6 Troubleshooting**

Describing the problems and possible answers for the *Industio* CP-114 Series.

## **Appendix**

Specification details, PCI, UART and DB37 pinouts are described.

# Table of Contents

<b>Introduction</b> .....	<b>1-1</b>
Overview .....	1-1
Features .....	1-3
Check List.....	1-3
Installation Guide.....	1-5
<b>Hardware Installation</b> .....	<b>2-1</b>
First Thing to Do: Interface Settings.....	2-1
Installing the <i>Industio</i> CP-114 Series Board .....	2-2
Connecting the Fan-out Cable .....	2-3
<b>Software Installation</b> .....	<b>3-1</b>
Windows NT .....	3-1
Installing Driver.....	3-1
Configuring Board and Port.....	3-6
Adding/Removing Board .....	3-7
Updating Driver.....	3-7
Removing Driver.....	3-7
Windows 95/98 .....	3-9
Installing Driver.....	3-9
First Time Driver Installation Stage .....	3-10
Port Configuration Stage.....	3-14
Board and Port Ready Stage.....	3-16
Configuring Board and Port.....	3-18
Updating Driver.....	3-19
Removing Driver.....	3-20
DOS .....	3-21
Installing Driver.....	3-21
Driver Setup.....	3-22
Loading Driver .....	3-26
Unloading Driver.....	3-26
<b>Serial Programming Tools</b> .....	<b>4-1</b>
<i>PComm</i> Installation.....	4-1

<i>PComm</i> Programming Library.....	4-1
Utilities.....	4-2
DOS .....	4-6
Installing API-232.....	4-6
DOS API-232 Library .....	4-6
Utilities.....	4-6
RS-485 Programming .....	4-9
Automatic Data Direction Control Mode .....	4-9
By RTS Mode .....	4-9
<b>Connection Cable and Cable Wiring.....</b>	<b>5-1</b>
RS-232 Cable Wiring .....	5-1
RS-422 Cable Wiring .....	5-4
RS-485 Cable Wiring .....	5-6
Impedance Matching and Termination Resistors.....	5-7
DB37 Connector .....	5-8
<b>Troubleshooting.....</b>	<b>6-1</b>
General Troubleshooting.....	6-1
Windows NT .....	6-2
Windows 95/98 .....	6-3
<b>Technical Reference.....</b>	<b>A-1</b>
Specification .....	A-1
PCI .....	A-1
UART 16C550C.....	A-2

## Overview

### *Industio* - Industrial Multiport Async Solutions for PCI

The term *Industio* stands for smart multiport serial I/O solution for industrial applications. The *Industio* CP-114 Series boards, including CP-114, CP-114I, CP-114S and CP-114IS, are RS-232/RS-422/RS-485 4-port serial communication interface boards for 32-bit PCI bus with “**Plug and Play**” feature. The *Industio* CP-114 Series support all three serial interfaces, RS-232, RS-422 and RS-485, in one board. Two of the four ports are RS-422/485 ports and the other two ports can be configured to RS-232 or RS-422/485 individually. Each RS-422/RS-485 port can control up to 32 devices in a multidrop environment. With this versatile design, it can control different kinds of serial device, such as modems, CNC and other industrial machines, without the need to use interface converters.

### PCI Solution

The board complies with PCI Spec. 2.1 and has neither switch nor jumper. The BIOS automatically assigns the hardware configuration for the IRQ number and memory addresses. Hence, the board **MUST** be plugged first before installing the software driver. For more PCI information, please refer to the Appendix, “Technical Reference”.

### Automatic Data Direction Control for RS-485

To ease the 2-wire RS-485 half-duplex control, Automatic Data Direction Control intelligence is built on *Industio* CP-114 Series board. Eliminating the need of software interference. Hence, the applications can manage the RS-485 port without extra code to control the half-duplex protocol.

With a well-designed and fine-tuned device driver, the *Industio* CP-114 boards make full use of the 32 byte Tx/Rx FIFO and on-chip H/W flow control, so that they can transfer data without loss even at high speed such as 921.6, bps. They offer a reliable and high performance solution for serial multiport communications.

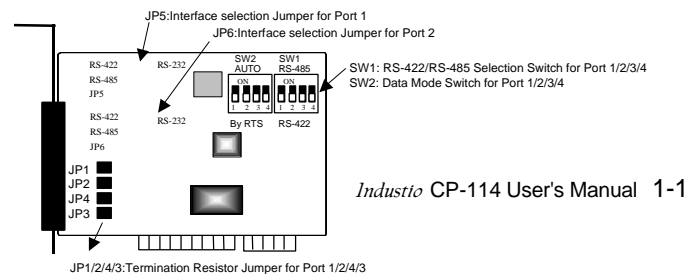

Industio CP-114 Series Board



### **Termination Resistors Ready for RS-422/RS-485**

Termination Resistors are already installed on the *Industio* CP-114 Series boards and no more headaches for finding proper resistors and connecting them for impedance matching problem. More details are in chapter, "Connection Cable and Cable Wiring".

### **Operating System Support**

Support for Windows NT, Windows 95/98 and DOS with user-friendly installation, configuration and performance.

### **MOXA Serial Comm Tools**

For application development, MOXA provides an easy-to-use serial communication library under Windows NT, Windows 95/98 (*PComm*) and DOS (**API-232**). Users can use this library to develop your own applications using Microsoft C, Turbo C, Assembly, QuickBASIC, Turbo Pascal, Clipper, Visual Basic, Visual C++, Borland Delphi, etc. Utilities, such as diagnostic, monitor, terminal emulator, etc., are included for debugging or monitoring the communication status or terminal emulator, or even file transferring.

### **Surge/Isolation Protection**

To meet the demand of high reliability in industrial environment and to prevent the boards from damage caused by lightning or high potential voltage, an optical isolation option (2KV DC) and surge block option (25KV ESD) are available. This is critical to harsh environment such as factory.

### **Broad Applications**

The board is suitable for many applications. Here are a few:

- Multipoint data acquisition
- Factory automation
- Remote serial device control

- Industrial control
- Embedded industrial machine
- SCADA

## Features

The *Industio* CP-114 Series features:

- ❖ Support PCI, Plug and play, no switch, no jumper, easy installation
- ❖ Support all three serial interfaces in one board (Port 1,2 for RS-232 or RS-422/485; Port 3,4 for RS-422/485).
- ❖ Compact size design, (half-size).
- ❖ High speed 16C550C Communication Controllers with on-chip hardware flow control guarantees no data loss and data integrity.
- ❖ High speed up to 921.6K bps each port.
- ❖ Support optical isolation, max. 2000V (RS-422/485)
- ❖ Support surge protection (25KV ESD) for all signal lines to prevent interference and noise and protect your system and minimize the system down time.
- ❖ Support 2-wire RS-485 half-duplex operation.
- ❖ Automatic Data Direction Control (ADDC) intelligence to simplify the RS-485 software programming.
- ❖ RS-485 data control: Auto (ADDC) or by RTS.
- ❖ Termination Resistors already installed on-board, no headache for impedance matching.
- ❖ Compatible with PC standard COM ports.
- ❖ Powerful Serial Comm tool - *Pcomm* and API-232.
- ❖ Support popular OS - Windows NT, Windows 95/98 and DOS

### CP-114 Series

Windows NT	✓
Windows 95/98	✓
DOS	✓

✓: Driver supported by Moxa and shipped with product

Note: Download the newest drivers from the MOXA FTP service

## Check List

Upon unpacking the *Industio* CP-114 Series, you should find items in the package:

- ❖ *Industio* CP-114 Series 4 ports serial board × 1
- ❖ MOXA Software CD-ROM × 1, which includes:
  - Drivers for MOXA Multiport Async Products

- 
- *PComm Lite* programming library and utilities for Windows NT/95/98
  - API-232 programming library and utility for DOS
  - User' s Manual (PDF)
  - ❖ *Industio* CP-114 Series User' s Manual (This manual)
  - ❖ Fan out cable DB37 to 4 × DB9 (Male)

## Installation Guide

This section gives a brief summary of how to install the *Industio* CP-114 Series under each supported operating system. The installation is simple and involves the following stages:





# 2

## Hardware Installation

The installation of the *Industio* CP-114 Series consists of hardware and software installation. The respective sections of the operating systems in the next chapter deal with the software installation. The hardware installation is detailed in this chapter.

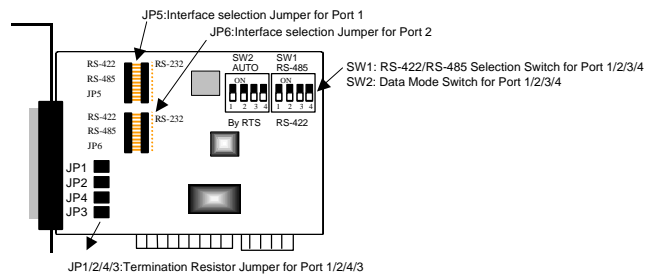

*Industio* CP-114 Series Board

### First Thing to Do: Interface Settings

Before installing the board into the slot, you should set all the jumpers to what you want. **The default (factory) settings: Port 1, Port 2, Port 3 and Port 4 RS-485, Automatic Data Direction Control mode, no Termination Resistor, indicated as \*.**

- JP5/6 Interface Selection Jumper for Port 1/2:
  - Left \*** Set the port interface to RS-422/RS-485.
  - Right** Set the port interface to RS-232.
- S1 RS-422/485 Selection Switch for Port 1/2/3/4:
  - ON \*** Set the port interface to RS-485.
  - OFF** Set the port interface to RS-422.

- 
- S2 Data Mode Selection Switch for Port 1/2/3/4:  
**(Valid if JP5/6 is Left and S1 is ON)**
    - ON\*** Set the RS-485 port to Automatic Data Direction Control Mode.
    - OFF** Set the RS-485 port to By RTS Mode.
  - JP1/2/3/4 Termination Resistor Port 1/2/3/4:  
**(Valid if JP5/6 is Left and S1 is ON)**
    - Open \*** Not using Termination Resistor
    - Short** Using Termination Resistor

## Installing the *Industio* CP-114 Series Board

The BIOS automatically assigns the IRQ number and I/O addresses for the *Industio* CP-114 Series board. Hence, it is a must to have the board plugged first before installing the software driver. After this, simply install the control board into the PC and then connect the connection cable.

**Step 1:** Power off the PC.

<b>Warning !</b>	Make sure your system is switched off before you start installing any board. If you don't, you may risk damaging your system and the board.
------------------	---

**Step 2:** Remove the slot cover bracket if present.

**Step 3:** Plug the *Industio* CP-114 Series control board firmly into a free 32-bit PCI slot.

**Step 4:** Fasten the holding screw to fix the control board in place.

### Connecting the Fan-out Cable

**Step 5:** Connect the fan-out cable (DB37 to DB9 x 4).

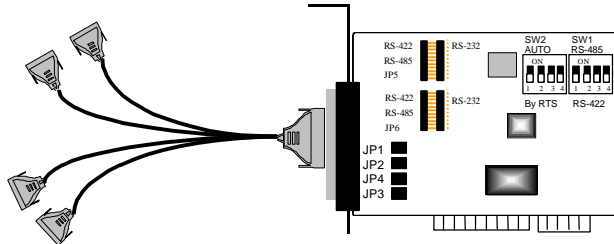

**Fan-out Cable** *Industio CP-114*

**Step 6:** Power on the PC and the BIOS will automatically set the IRQ and I/O address.

**Note**

Each board must occupy one unique IRQ and four 8-byte I/O addresses, which are assigned automatically by the BIOS. However, you can select a free IRQ number manually via the PC's BIOS setup for the PCI slot, but normally this method is not available for the I/O address. The possible IRQ numbers are 2, 3, 4, 5, 7, 10, 11, 12, and 15. The possible I/O addresses are from 0x0000 to 0xFFFF.

**Step 7:** Proceed with the software installation detailed in the next chapter, "**Software Installation**".



# 3

## Software Installation

---

In this chapter, the software driver installation, configuration and driver update/removal procedures are described for various operating systems, including Windows NT, Windows 95/98 and DOS. Before proceeding with the software installation, complete the hardware installation detailed in previous chapter.

However, if it is necessary for you to develop your own applications, please refer to the next chapter, "Serial Programming Tools", for serial programming issues.

### Windows NT

Windows NT supports up to **256** serial ports, from **COM1** to **COM256**. To fully integrate the advanced features of Windows NT, multi-process and multi-thread, pure 32-bit Windows NT device drivers are developed for the *Industio* CP-114 Series and other MOXA multiport boards. The drivers conform to Win32 COMM API standard.

If you install the driver for the first time, please go directly to the section "Installing Driver".

If you have already installed the driver and want to re-configure the board and port, please refer to the section, "Configuring Board and Port".

If you have already installed the driver and want to add or delete boards, please refer to the section, "Adding/Removing Board".

If you want to update or even remove the driver, please go to the section, "Updating Driver", or the section, "Removing Driver".

### Installing Driver

Following is the procedure for installing the *Industio* CP-114 Series driver **for the first time** under Windows NT 3.51/4.0. Make sure the board(s) has(have) already been plugged in the system PCI slot(s).

1. Please log in NT as **Administrator**.

2. Open the [Control Panel], click on the [Network] icon and select the [Adapters] tab.
3. Click on the [Add] button, then the [Have Disk...] button in “Select Network Adapter”.
4. Specify the exact path of the driver diskette, A:\WINDOWS.NT. Then click [OK].

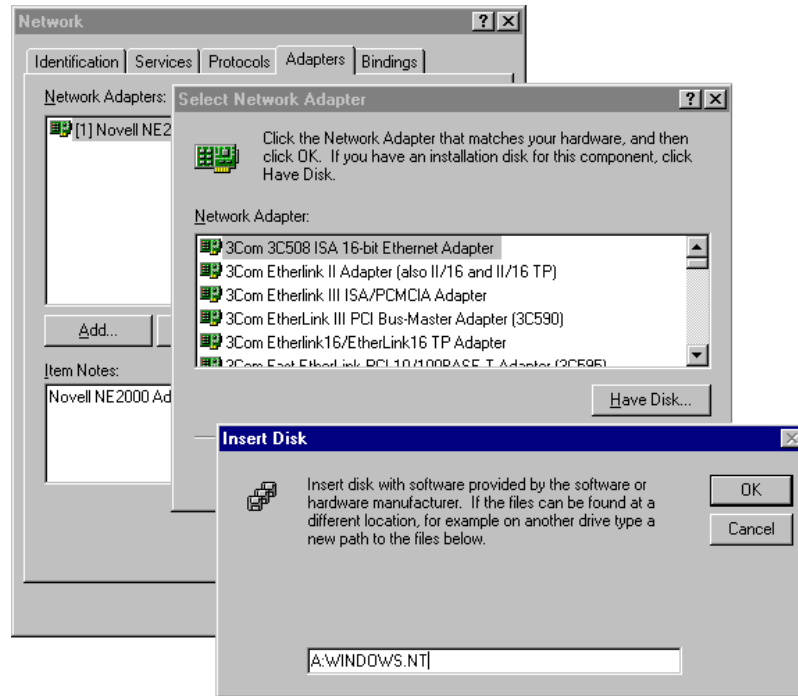

## Software Installation

5. Select “**MOXA Smartio/Industio Family multiport board**” in the “Select OEM Option” dialog box, and click [OK] to enter the “**Moxa Smartio/Industio Configuration Panel**” dialog box to start the installation.

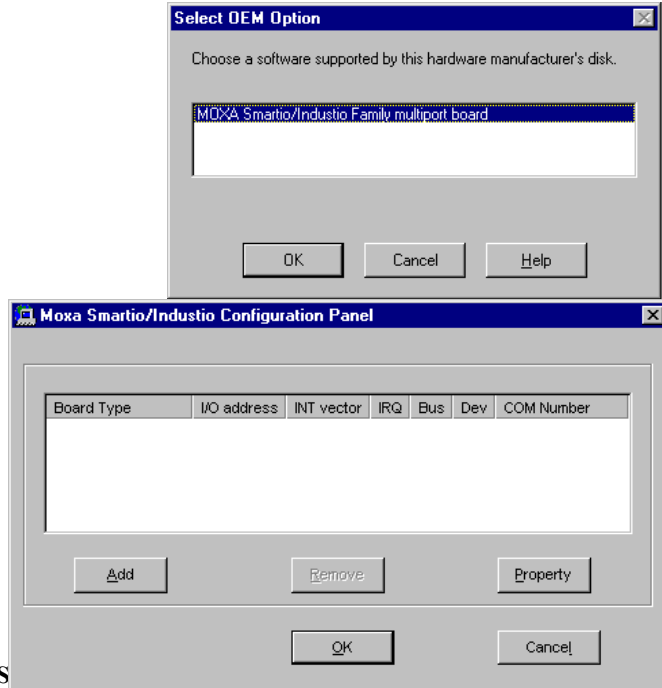

6. In the “**Moxa S**” “**Property**” dialog box to add the *Industio* CP-114 Series board. Select the “**CP-114 Series**” in the “Board Type” field. In the “**Property**” dialog box, the COM number field of the newly installed board is set to **default COM No.** If necessary, you may select to change all the ports of the board with the desired “**COM Number**”.

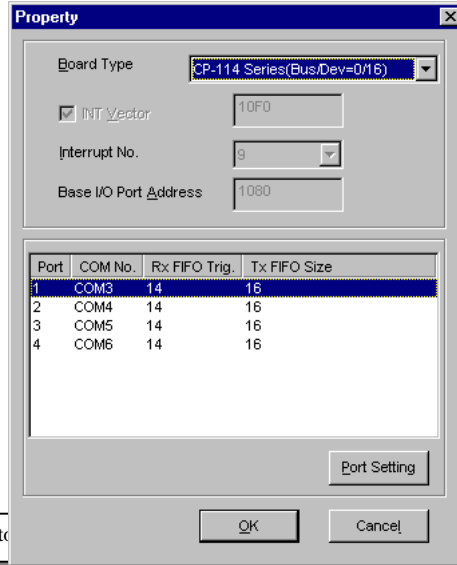

**Note** You may go directly to

- In the “**Property**” dialog box, select the desired port in the port list and click [**Port Setting**] to enter the individual “**Port #**” setting dialog box to change the port number mappings or FIFO settings.

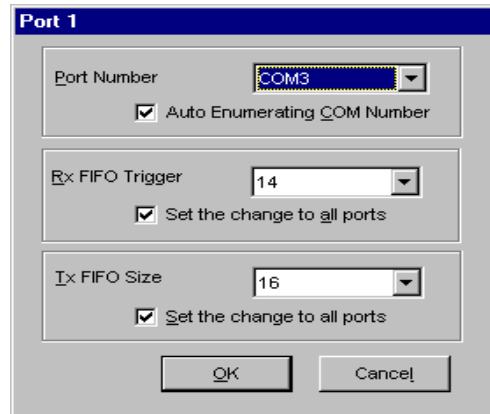

- **Port Number**

You have to set up all the ports of the board with the desired “**COM number**”, which should not conflict with other COM number in use. In this “Individual Port Setting” dialog box, you may have two ways to map the physical ports to COM numbers depending on the check box “**Auto Enumerating COM Number**”.

## Software Installation

If “Auto Enumerating COM Number” is checked and specify the COM number of the first port, subsequent ports are mapped to continuous COM numbers. For instance, if first port is mapped to COM3, then second port is mapped to COM4 sequentially.

If “Auto Enumerating COM Number” is not checked, specify the COM number for individual port. For instance, the second port can be out of sequence, say COM10, while the first port is mapped to COM3.

- **Rx FIFO Trigger**

Rx FIFO trigger levels, at 1, 4, 8 or 14 bytes, are available, and the default value is 14 bytes.

- **Tx FIFO Size**

Tx FIFO sizes from 1 to 16 bytes are available, and the default value is 16 bytes.

8. Click [OK] in the “Port #” and the “Property” dialog boxes to go back to the “Moxa Smartio/Industio Configuration Panel” dialog box.

**Note** If you need to install more than one board, click [Add] and repeat steps 6 to 8 to configure another board. Up to four *Industio* CP-114 Series boards can be installed in a system.

Click [OK] to finish the configuration.

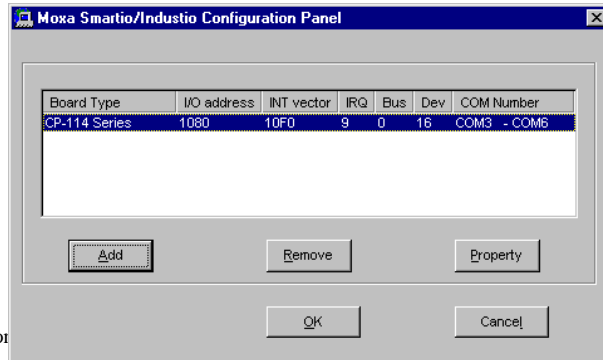

9. When configuration

10. Restart Windows NT system. The latest configuration will not take effect unless the system restarts.

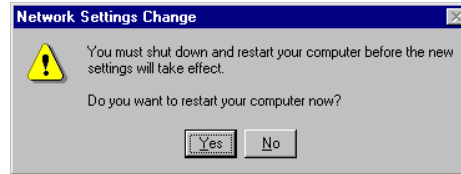

**Note** The latest configuration will not take effect unless the system restarts.

11. Once the system restarts, you may check the event log issued by the MOXA driver to see if the ports of the board are initialized successfully.
  - Enter the [Administrative] group, click on the [Event Viewer] icon and select [Log] and [System] to check a message similar to “MOXA CP-114, with first serial port COM3, has been enabled” for each configured board.
  - If an error message similar to “Cannot find any configured MOXA CP-114 board!” appears, refer to the “Troubleshooting” chapter for solutions.

**Note** Once the board and the driver are installed and the driver restarts successfully, you can start to develop applications with the *PComm* library (See “Serial Programming Tools”) or the Microsoft Win32 API. You can also execute any ready-made applications, such as *PComm* utility Terminal emulator (See “Serial Programming Tools”) or HyperTerminal to transmit/receive data, as well as Remote Access Service to provide dial-up networking capabilities.

## Configuring Board and Port

If you already have installed the driver and want to re-configure the ports, please follow this procedure.

1. In the [Control Panel], click on the [Network] icon and select the [Adapters] tab.
2. Select “MOXA Smartio/Industio Family Adapter” in “Network Adapters”.

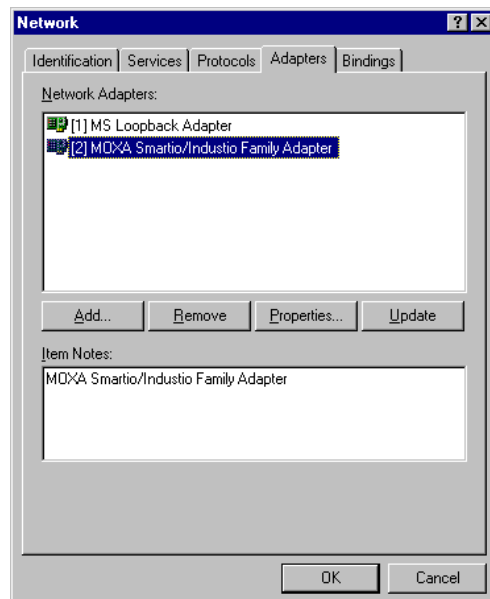

3. Click on the **[Properties]** button to open the “**Moxa Smartio/Industio Configuration Panel**” dialog box. Please see steps 6-10 in the previous section, “Installing Driver”, for more details.

### Adding/Removing Board

Following is the procedure to add/remove *Industio* CP-114 boards after a first time installation. Note that **the presence of the board(s) is(are) required for adding/removing boards.**

1. Power off the system.
2. Plug/unplug the boards in the system.
3. Power on the system.
4. Run the software configuration to setup the boards, as shown in the previous section.

### Updating Driver

To update the driver for the *Industio* CP-114 board, simply remove the driver, as described in the next section, and then reinstall it as detailed in the “**Installing Driver**” section.

### Removing Driver

To remove the driver for the *Industio* CP-114 board,

1. Open the **[Control Panel]**, click on the **[Network]** icon, and select the **[Adapters]** tab.

- 
2. Select “**MOXA Smartio/Industio Family Adapter**” in the adapter list, then click on the [**Remove**] button and the [**OK**] button to remove the driver.
  3. Restart the system to activate the new configuration.

### Windows 95/98

Windows 95/98 supports up to **128** serial ports, from **COM1** to **COM128**. To fully integrate the advanced features of Windows 95/98, multi-process and multi-thread, pure 32-bit Windows 95/98 virtual device port drivers (VxD) compliant with communication drivers (VCOMM) are developed for the *Industio* CP-114 Series and other MOXA multiport boards. The drivers conform to the Win32 COMM API standard.

If you install the driver for the first time, or you want to add more boards, please go directly to section, "Installing Driver".

If you have already installed the driver and want to re-configure the board, please refer to section, "Configuring Board and Port".

If you want to update the driver, please go to section, "Updating Driver".

If you want to remove the driver, please go to the section, "Removing Driver".

### Installing Driver

If you install for the first time, or you want to add more boards, this section is for you.

You can easily plug the *Industio* CP-114 board and work right away with very little installation efforts under Windows 95/98, which supports **Plug and Play** capability. Windows 95/98 will automatically detect the presence of the newly plugged board and prompt you to install the software driver the first time. In this case, you need the driver diskette.

Up to 4 *Industio* CP-114 Series boards can be installed together as long as the I/O addresses and IRQ number resources are sufficient and available in a system.

---

The following flow chart illustrates the driver installation stages of the *Industio* CP-114 Series boards. Each stage is detailed later.

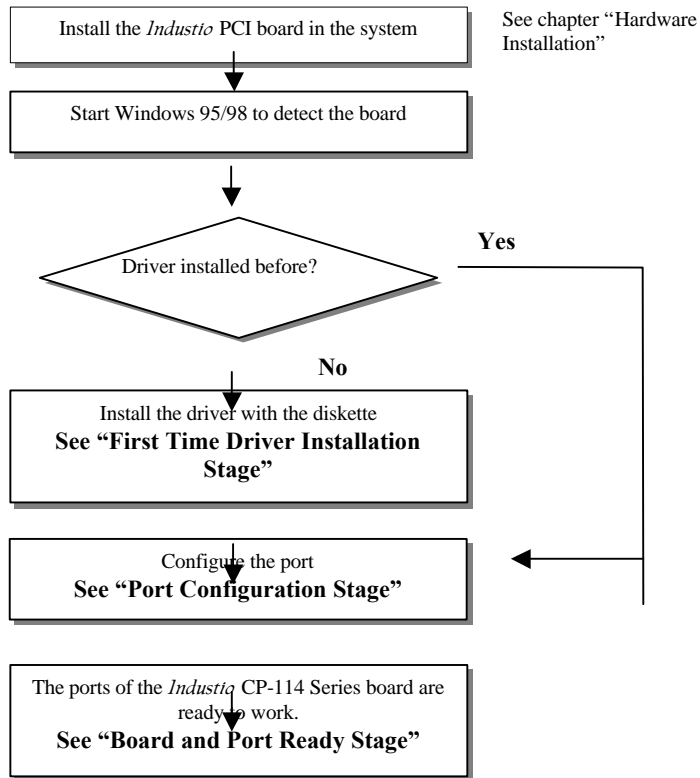

### First Time Driver Installation Stage

This stage presents the steps for installing the driver for the very first time with the first *Industio* CP-114 Series board. The installation of the *Industio* CP-114 Series board for Windows 95 and Windows 98 **differs slightly** and will be described in two columns. **Follow the steps in the left or right column for Windows 95 or 98, respectively.**

## Software Installation

1. Upon detecting the first new *Industio CP-114 Series board*, Windows 95/98 will automatically show a “New hardware found” message box, and then display the following dialog box. Click on the [Next>] button.

### Windows 95



2. Click on the [Other Locations] button.

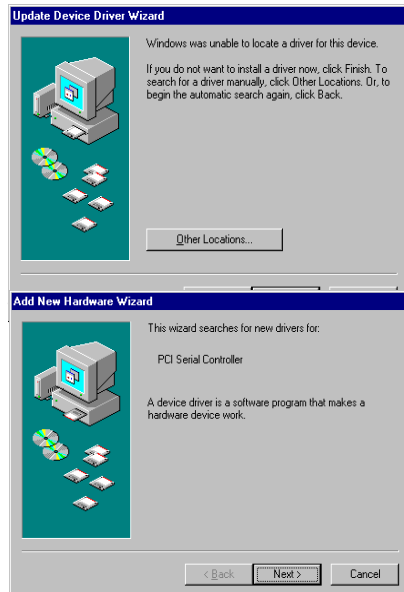

3. Type “A:\Windows.95” in the Location field, and click [OK] button. The system will start reading the files from the diskette.

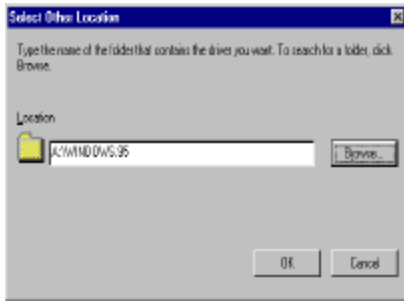

4. Click on the [Finish] button.

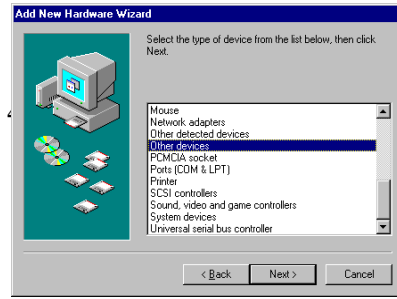

5. Type “A:\Windows.95” and click [OK] button. The diskette.

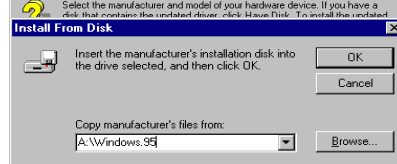

3. Select “Other Devices” and click [Next>] button.

## Software Installation

6. Click [Next>] button.

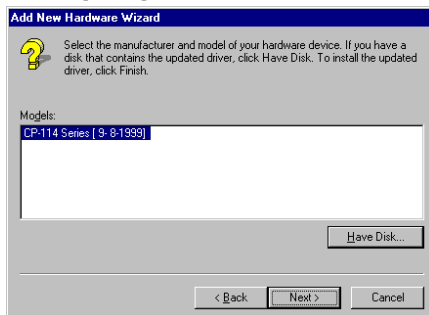

7. Click [Next>] button.



## Port Configuration Stage

This stage displays the “CP-114 Series Installation” dialog box for the port configuration. Here you can map the MOXA ports to the system COM numbers.

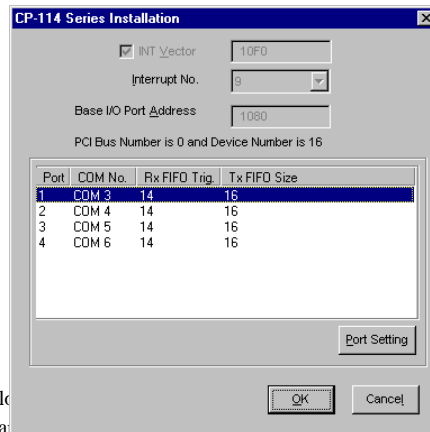

In the “CP-114 Series Installation” dialog box, the COM board is set to **default COM No.** If necessary, you can change it with the desired “COM Number”.

**Note** You may go directly to the **next stage** if you need not change any setting.

In the “CP-114 Series Installation” dialog box, select the desired port in the port list and click [**Port Setting**] to enter the individual “Port #” setting dialog box to change the port number mappings or FIFO settings.

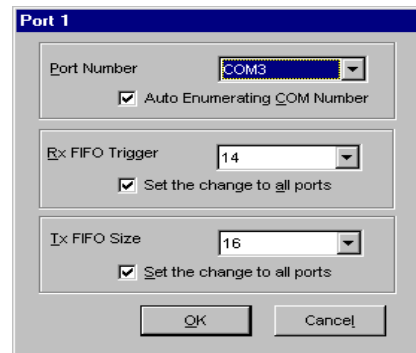

- **Port Number**

You have to set up all the ports of the board with the desired “COM number”, which should not conflict with other COM number in use. In this “Individual Port Setting” dialog

## Software Installation

---

box, you may have two ways to map the physical ports to COM numbers depending on the check box “**Auto Enumerating COM Number**”.

If “Auto Enumerating COM Number” is checked and specify the COM number of the first port, subsequent ports are mapped to continuous COM numbers. For instance, if first port is mapped to COM3, then second port is mapped to COM4 sequentially.

If “Auto Enumerating COM Number” is not checked, specify the COM number for individual port. For instance, the second port can be out of sequence, say COM10, while the first port is mapped to COM3.

- **Rx FIFO Trigger**

Rx FIFO trigger levels, at 1, 4, 8 or 14 bytes, are available, and the default value is 14 bytes.

- **Tx FIFO Size**

Tx FIFO sizes from 1 to 16 bytes are available, and the default value is 16 bytes.

---

## Board and Port Ready Stage

Click [**OK**] for all the dialog boxes to finish the configuration and exit the “**CP-114 Series Installation**” dialog box.

In this last stage, you will complete the driver installation.

### Windows 95

After the port installation, you can **immediately** use the COM ports of the *Industio* CP-114 Series board **without restarting Windows 95 system**.

### Windows 98

After the port installation, click on the [**Finish**] button. Now you can **immediately** use the COM ports of the *Industio* CP-114 Series board **without restarting Windows98 system**.



## Software Installation

---

Once the installation is finished, error conditions of the board, **if any**, are displayed on the screen. Otherwise, everything should be fine.

If an error message similar to “CP-114 (BusNo=x, DevNo=x, Port1=COMx) interrupt number is invalid!” appears, refer to the “Troubleshooting” chapter for solutions.

**Note !** Up to now, the driver installation of the *Industio* CP-114 Series is complete and successful, including the board and port configuration. However, if changes of the board and port configuration are needed, please refer to the next section, “Configuring Board and Port”, for more configuration details.

~~**Note !** Once the board and the driver are installed and the driver restarts successfully, you can start to develop applications with the *PComm* library (See “Serial Programming Tools”) or the Microsoft Win32 API. You can also execute any ready-made applications, such as *PComm* utility Terminal emulator (See “Serial Programming Tools”) or HyperTerminal to transmit/receive data, as well as Remote Access Service to provide dial-up networking capabilities.~~

- ~~• If multiple boards are installed at the same time, the same scenario applies for the next boards, except that no driver diskette is asked anymore.~~
- Similarly, if you want to add more boards and the driver has been installed before, simply plug the *Industio* CP-114 Series board and Windows 95/98 will automatically detect and install the required driver.

---

## Configuring Board and Port

If you already have installed the driver and want to re-configure the COM number for the ports under Windows 95/98, follow this procedure.

1. Open the [Control Panel], click on the [System] icon, select the [Device Manager] tab, and then [MOXA Smartio/Industio multiport board]. Select the desired [CP-114 Series] entry, click on the [Properties] button and select the [Ports Configuration] tab.

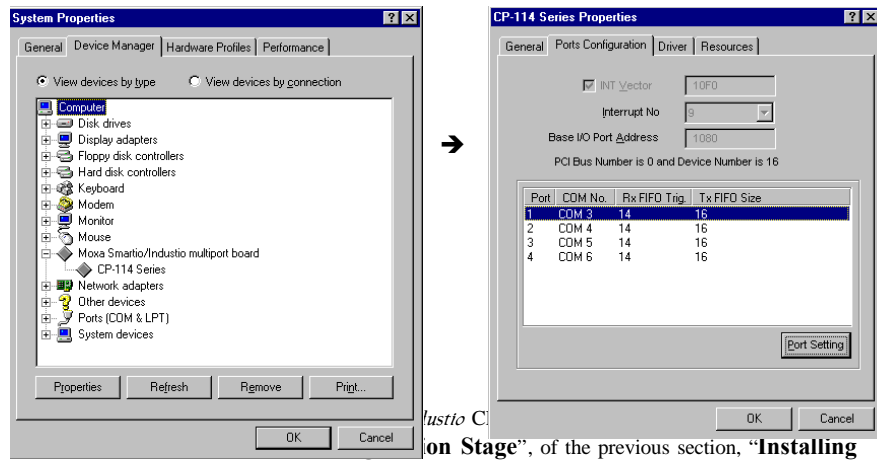

Driver".

3. Restart the system to activate the latest configuration.

### Updating Driver

This section explains how to update the driver.

1. In the [Control Panel], click on the [System] icon, select the [Device Manager] tab and select [MOXA Smartio/Industio multiport board].
2. Select the “CP-114 Series” option. Click on the [Properties] button and then select the [Driver] tab.
3. Click on the [Update Driver...] button. Click then on the [Have Disk...] button to type the path of the new driver and update the driver.
4. Restart the system to activate the new configuration.

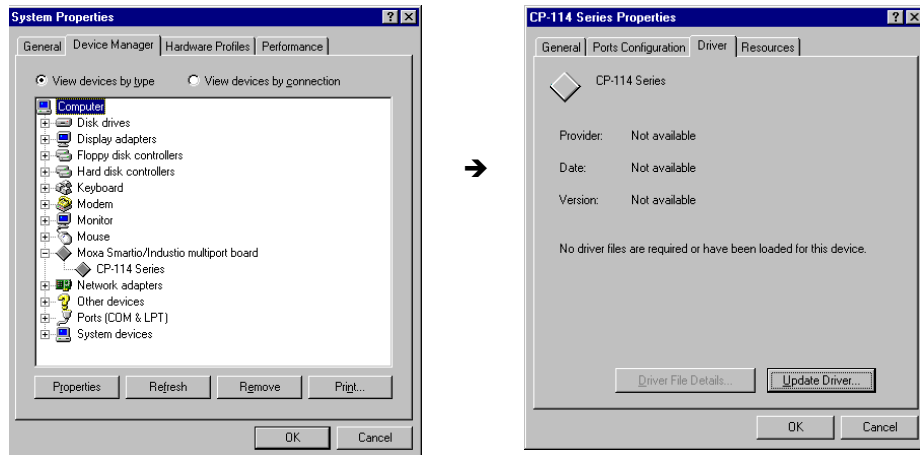

---

## Removing Driver

This section explains how to remove the Industio CP-114 Series board driver.

1. Open [Control Panel] icon, double click [Add/Remove Programs] icon, and then select [Install/Uninstall] tab.
2. Click on MOXA Smartio/Industio Driver option and then click [Add/Remove] button to start the driver removal.

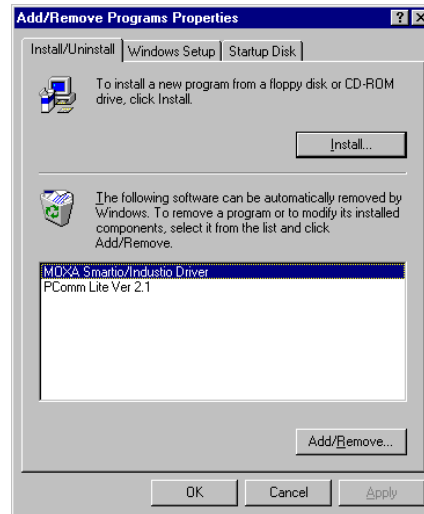

3. Click [Yes] button in the following shown message box to confirm the driver removal.

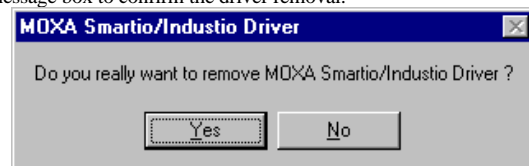

4. Click [OK] button in Add/Remove Programs Properties dialog box.

### DOS

MOXA DOS API-232 is a software package that assists users to develop and/or debug programs for serial communications. This section will show you how to install the package, how to setup up the driver, and how to load or unload driver.

For details of the serial programming (API-232 Library) and utilities, please refer to the next chapter, "Serial Programming Tools".

### Installing Driver

Run the installation program, **DOSINST.EXE**, in the DOS driver diskette. Specify the target API-232 directory (e.g. **C:\MOXA**) where software driver will be copied. Press **F2** to start the installation.

After installation is complete, you will be prompted to proceed running setup program. It is strongly recommended to do so.



---

## Driver Setup

The following are steps for setting up the *Industio* CP-114 Series driver. Note that it is not intended to illustrate all the convenient functions of the setup programs when configuring the boards.

1. Run the setup program, **BIN\SETUP.EXE**, in the API-232 directory.
2. Press **Enter** to pop up the SETUP dialog box. In the SETUP dialog box, select the “CP-114 Series” in the “Type” field and set up all the ports of the board with the desired “Port number”, which should not conflict with other port number in use.



## Software Installation

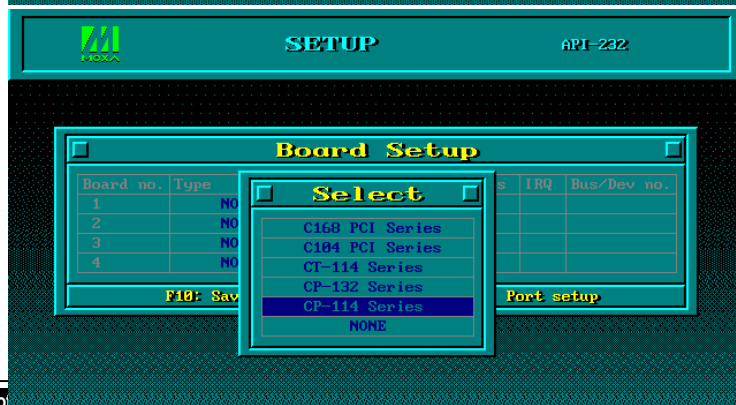
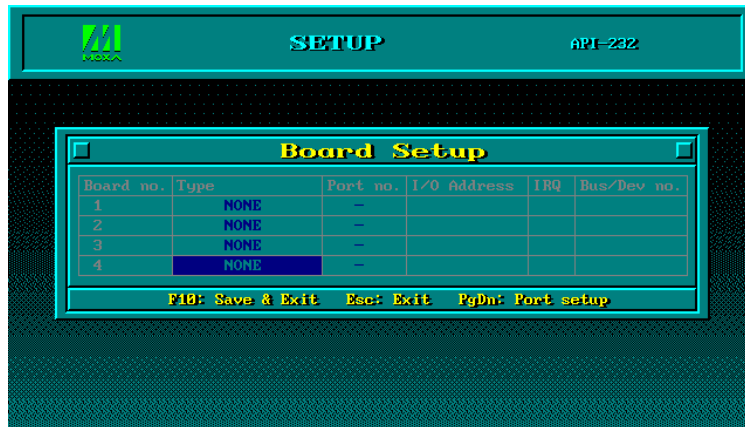

No.

may skip this step and go directly to the next **step 5** if you need not change any setting or configure any board.

- You may now enter/modify each port's configuration. These displayed values are the port initial values as driver is loaded.

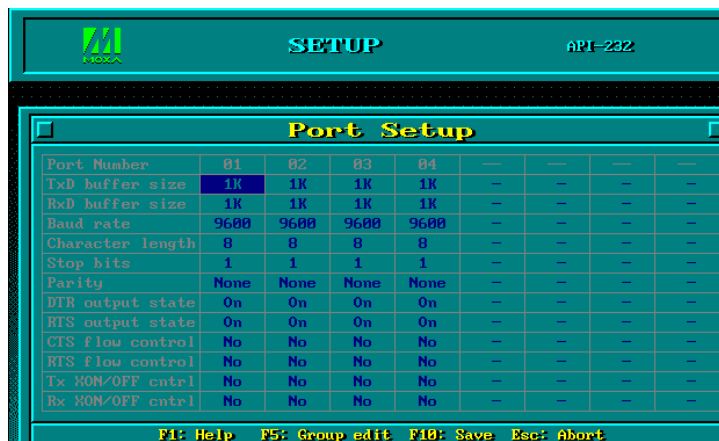

**Legend:** Some noticeable fields and functions are explained below.

**Port number:** This is actually the port ID of each port. The application software will refer to the port by its port number (ID). Duplicated port number is not allowed. That is, each MOXA serial port is referred to as port number in terms of serial programming.

You may map the port number range to the one you prefer between 0 and 255 as long as no port number overlapping condition or port number undefined condition occurs. Generally, you should take the convenience of programming into consideration when specifying the port numbers for the board.

**TxD buf size:** The transmit (output) buffer allocated in the system for each port.

**RxD buf size:** The receive (input) buffer allocated in the system for each port.

**F5: Group edit:** This is a convenient function that helps you edit the configuration of several ports at one time as a group.



## Software Installation

- To setup more boards, please follow the same instructions **2** to **3** described above.
- Press F10 to save the latest configuration and exit the SETUP program.



---

## Loading Driver

Having completed the setup, you can load the driver, "**BIN\DP-DRV.EXE**", at the DOS prompt. The driver will detect the *Industio* CP-114 Series board automatically. If the board(s) is(are) detected, a message similar to below will show:

```
Smartio/Industio Family DOS driver Version 1.1
Setup driver...
CP-114 series (Bus=0, Dev=11): O.K.!
Device driver setup O.K.
```

It means the *Industio* CP-114 Series driver is installed properly. At this point, you are ready to execute application that supports API-232 functions, or start developing applications using API-232 library.

If something went wrong, for instance, the board does not match the configuration or the board is missing, the screen will show a message like:

```
Smartio/Industio Family DOS driver Version 1.1
Setup driver...
CP-114 series (Bus=0, Dev=11): Board not Found.!
Setup none port !!
```

It means the *Industio* CP-114 Series driver is not installed properly. Please refer to chapter, "Troubleshooting", for possible reasons and solutions.

## Unloading Driver

To unload (release) the *Industio* CP-114 Series driver from memory, type "**DP-DRV/Q**" at the DOS prompt.

# 4

## Serial Programming Tools

---

Moxa supports some easy but powerful serial programming libraries and communication troubleshooting utilities under Windows NT and Windows 95/98. You will save a lot of developing time with the MOXA Serial Programming Tools.

The following sections will detail the installation, the library and the utilities for various platforms.

*PComm*, the professional serial comm tool for PC, is a software package for **Windows NT and Windows 95/98**. It consists of a powerful serial communication library for easy programming in the most popular languages, useful utilities such as diagnostic, monitor and terminal emulator, illustrative sample programs and comprehensive on-line documents.

The serial communication library is useful for developing a system for data communication, remote access, data acquisition or industrial control in the Windows NT and Windows 95/98 environment, for an easier solution compared to the more complex Windows Win32 COMM API.

### *PComm* Installation

To install *PComm*, run **Setup.exe** from the diskette. Note that the *PComm* diagnostic and monitor utilities are for MOXA boards only. MOXA Windows NT or Windows 95/98 device drivers, as well as MOXA boards are required. The drivers are installed separately and detailed in the "Software Installation" chapter.

Click [**Start**] and select [**Program Files**] and the [**PComm Lite**] group to see a list of utilities and documents.

### *PComm* Programming Library

The serial communication library helps you to develop programs for serial communications **for any COM port** complying with Microsoft Win32 API. It facilitates the implementation of multi-process and multi-thread serial communication programs and hence greatly reduces developing time.

For a complete library function description and sample programs for Visual C++, Visual Basic and Delphi, please click [**Start**] and select [**Program Files**] and [**PComm Lite**] and [**PComm**

---

**Library Help**, [**PComm Porting Notes**] or [**PComm Programming Guide**] or refer to the sample programs in the *PComm* directory.

## Utilities

Following are short descriptions of each utility. For details, please see the on-line help on the diskette.

## Serial Programming Tools

### Diagnostic (for MOXA boards only)

A convenient diagnostic program that provides internal and external testing, such as IRQ, TxD/RxD, UART, CTS/RTS, DTR/DSR, DTR/DCD testing, etc., for the MOXA boards and ports to verify correct operations of both the software and hardware.

Click [**S**tart] and select [**P**rogram Files] and [**P**Comm Lite] and [**D**iagnostics].

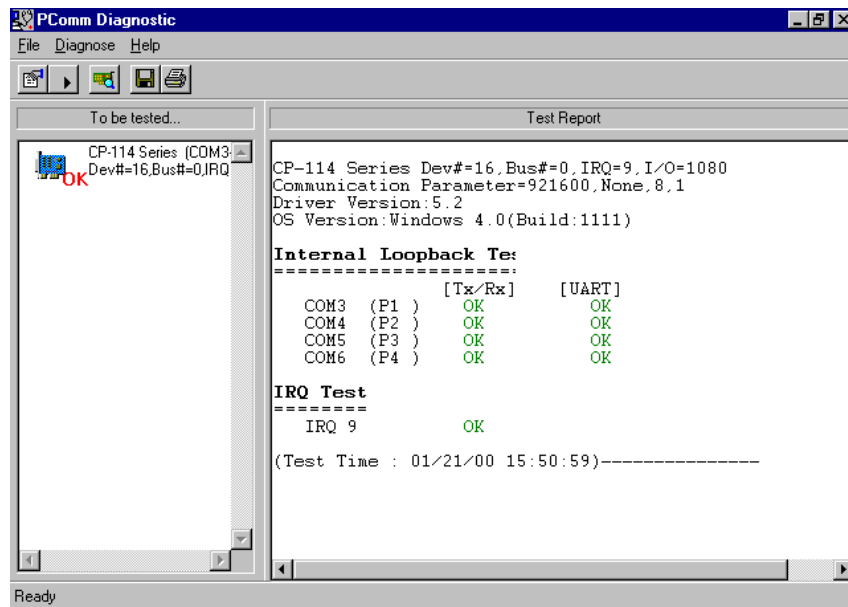

---

## Monitor (for MOXA boards under Windows NT Only)

A useful port status monitoring program that allows you to watch the selected MOXA COM ports' data transmitting/receiving throughput and communication line status which are updated and displayed on the screen at time intervals. You can also click on one of the specific displayed port in order to visualize the current communication parameters and status of that port.

Click **[Start]** and select **[Program Files]** and **[PComm Lite]** and **[Monitor]**.

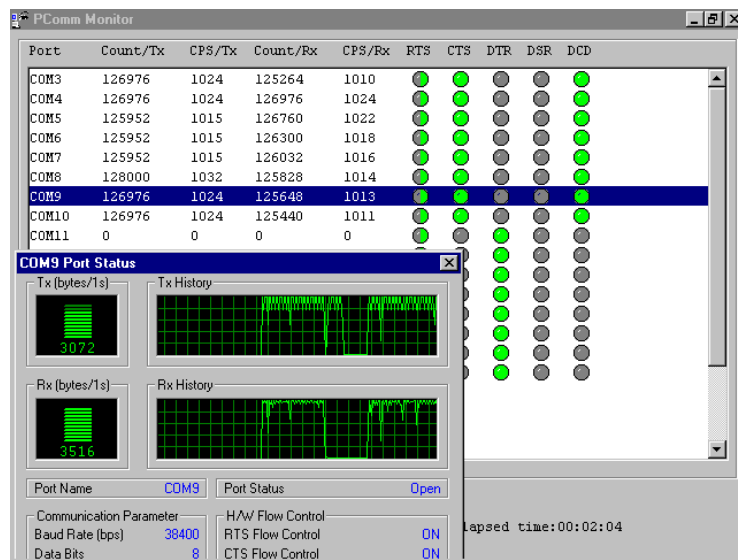

## Serial Programming Tools

### Terminal Emulator

The Terminal Emulator features multi-windows and supports terminal types of VT100 and ANSI. You can transfer data interactively, send pattern periodically or transfer file using ASCII, XMODEM, YMODEM, ZMODEM and KERMIT protocols.

Click [Sta

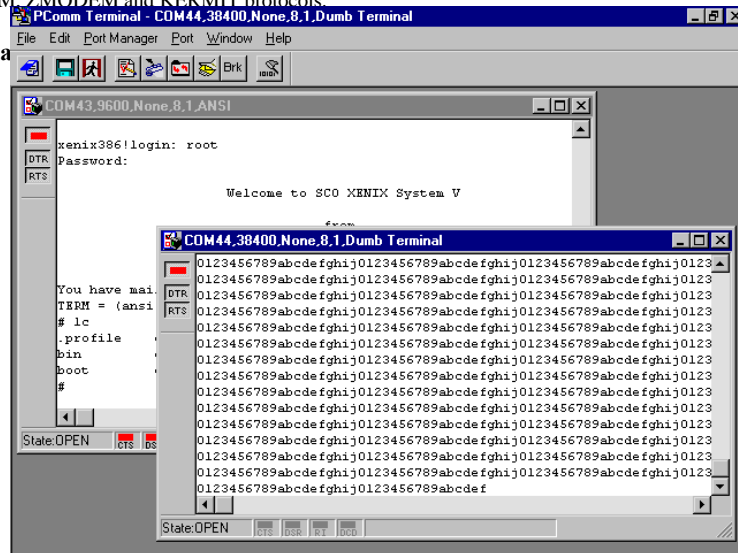

---

## DOS

### Installing API-232

API-232 Library is the professional serial programming tool for DOS. It is installed automatically along with the MOXA DOS drivers. The installation is detailed in Chapter "Software Installation".

### DOS API-232 Library

DOS API-232 library supports languages like Microsoft C, Turbo C, Macro Assembly, QuickBasic, Turbo Pascal, Clipper, etc. Sample programs for each supported language are included, and placed in the sub-directory, `..\EXAMPLE\language`, of the API-232 directory.

In addition, for DOS C language only, there are also Modem Control and File Transfer library available, supporting Hayes compatible modem control as well as ASCII, KERMIT, XMODEM, YMODEM and ZMODEM file transfer protocol functions.

For complete API-232 function description, please see file **API-232.TXT** in the API-232 directory for more details.

### Utilities

There are two utilities available for DOS: Data Scope and Diagnose, which are detailed below.

## Serial Programming Tools

### Data Scope

The Data Scope, **BIN\SCOPE.EXE**, is a suite of utility programs that can help users with system troubleshooting and serial communication debugging.

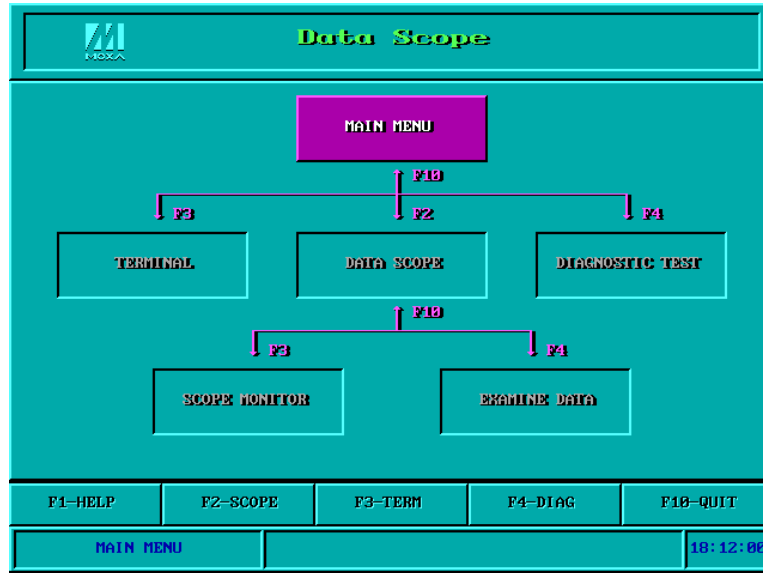

There are three major functions in Data Scope utility:

1. The **Data Scope utility** offers transparent monitoring of serial communication lines and allows data to be streamed to disk storage for later analysis.
2. The **TTY terminal emulation utility** allows user to view the signal status and transfer data interactively or files using ASCII, XMODEM, YMODEM, ZMODEM and KERMIT protocols.
3. The **Diagnostic test utility** provides port connection test with two MOXA ports connected via a properly wired cable.

Please see **on-line help** as running **BIN\SCOPE.EXE** for more usage and capability information.

### Diagnose

The Diagnose, **BIN\PCIDIAG.EXE**, is a utility that can help users to diagnose the hardware condition of each port of the selected board. See on-line help for more details.





### RS-485 Programming

If you intend to do RS-485 communication with *Industio* CP-114 Series, please follow the RS-485 programming guide below and also refer to the chapter, “**Connection Cable and Cable Wiring**”, for more RS-485 operation details.

The *Industio* CP-114 Series supports **only 2-wire half-duplex RS-485 communication**. **Data+/-** pins are served for both data transmitting and receiving, depending on the mode selected: either **Automatic Data Direction Control (ADDC)** or **By RTS** mode.

#### Automatic Data Direction Control Mode

**Automatic Data Direction Control** scheme is the best solutions for RS-485 applications. The data mode selection jumper for the port should be set to **Left** position, to be able to use Automatic Data Direction Control Mode.

Under this mode, no extra code is required to control the data transferring (data transmitting and receiving), which is automatically managed with the intelligent hardware mechanism. That is, **RS-485 programming in this mode is just as simple as RS-232/RS-422 programming**.

#### By RTS Mode

If the data mode selection jumper for the port is set to **Right** position, By RTS mode is used. The port is ready for transmitting data if **RTS signal is asserted** and ready for receiving data if **RTS signal is not asserted**.

**RTS** scheme is a traditional way and suitable for most system, including Windows NT , Windows 95/98 and DOS, that permits RTS control from application programs. This mode should be compatible with most of the already-made RS-485 applications.

#### How to transmit and receive data for Windows NT, 95/98 & DOS

We recommend you to configure *Industio* CP-114 Series ports as follows in order to acquire precise timing control in RS-485 2-wire transmission.

---

There are 2 solutions to control RS-485 2-wire transmission.

#### **Solution 1**

The following model is common in RS-485 2-wire transmission.

```
sio_SetWriteTimeouts(port, 0); /* Set sio_write() into block mode if for
                                Windows NT and Windows 95/98 */
sio_RTS(port, 1);             /* Turn on RTS signal. The RS-485
                                port is ready for transmitting data. */
sio_write(port, buff, 10);    /* Write 10 byte characters in "buff".
                                The function blocks until last character
                                transmitted */
sio_RTS(port, 0);           /* Turn off RTS signal. The RS-485
                                port is ready for receiving data. */
sio_read(port, buff, 10);    /* Read 10 bytes */
```

#### **Solution 2**

There is a dedicated RS-485 function in *PCComm* or API-232 library. It integrates the above functions of solution 1 regarding sending data as one.

```
sio_putb_x(port, buff, tick ); /* 1. Turn on RTS and ready for
                                transmitting data.
                                2. Send data.
                                3. Wait for tick time.
                                4. Turn off RTS and ready for
                                receiving data. */
```

For more information on these functions, please refer to *PCComm* library on-line Help file for Windows NT and Windows 95/98 or API-232.txt file for DOS, respectively.

# 5

## Connection Cable and Cable Wiring

---

In serial data communications, the term **DTE** is for Data Terminal Equipment, like PC COM1/2, serial printers and terminals. The term **DCE** is for Data Communication Equipment, like modems.

### RS-232 Cable Wiring

The followings are pin assignments for the DB9 RS-232 connector for **Port 1** and **Port 2** of *Industio* CP-114 Series.

#### CP-114 Series (DTE, DB9 Male)

---

1	DCD
2	RxD
3	TxD
4	DTR
5	GND
6	DSR
7	RTS
8	CTS

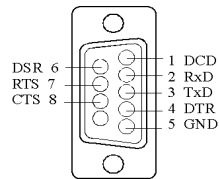

**Type 1: To connect the *Industio* CP-114 Series to a DTE device.**

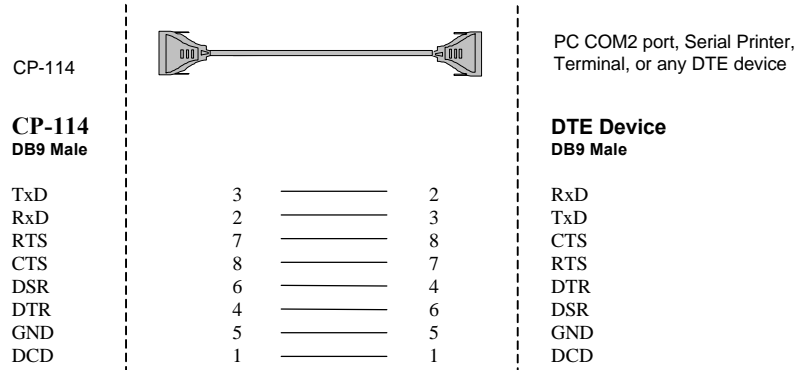
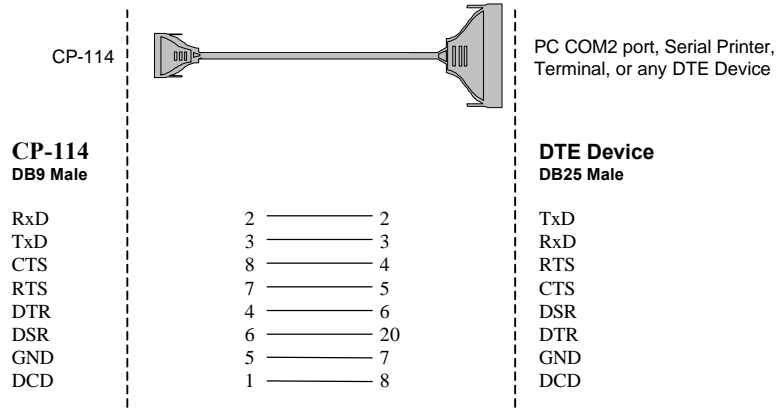

## Connection Cable and Cable Wiring

**Type 2: To connect *Industio* CP-114 Series to a DCE device.**

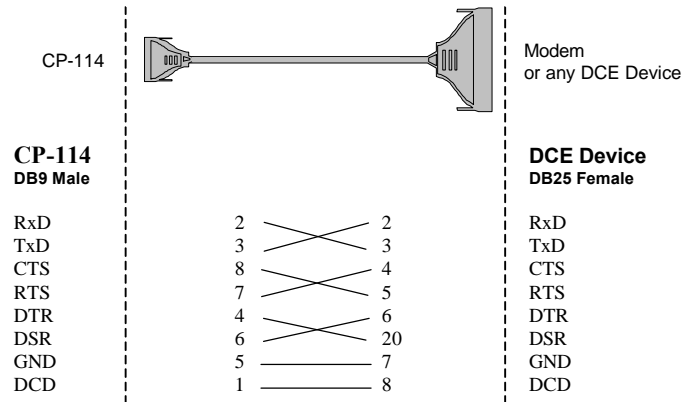

**Type 3: To connect *Industio* CP-114 Series to a DTE with 3-pin wiring.**

If the [**Hardware flow control**] feature is set to “**ON**”, you must loop back (or short) the RTS with CTS and the DSR with DTR, DCD on the MOXA site.

If [**Hardware flow control**] feature is set to “**OFF**”, you could just leave RTS, CTS, DSR, DTR, DCD open, ignoring the connection indicated in dash-lines.

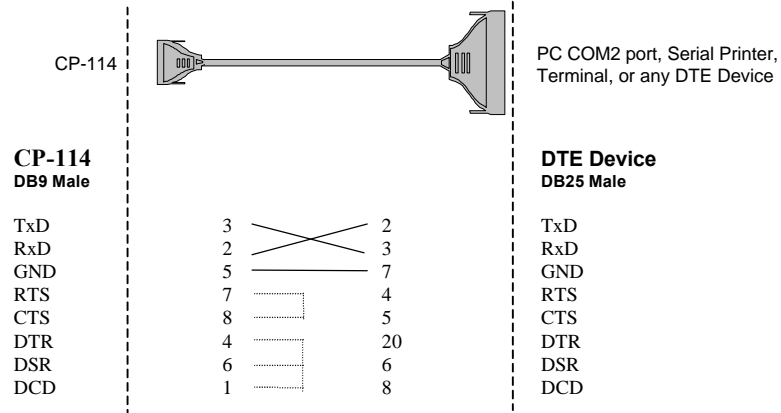

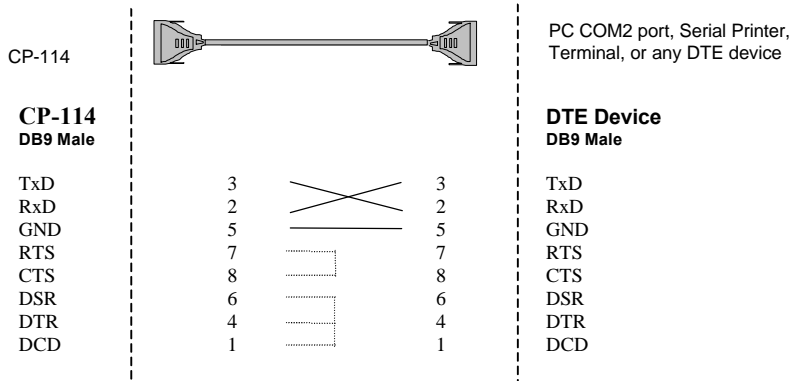

## RS-422 Cable Wiring

The RS-422 standard uses a balanced voltage digital interface to allow communications of 10M bps on cable length of 40 feet. Ten receivers can be connected to any one driver for broadcasting systems.

RS-422 pin outs for *Industio* CP-114 Series:

**CP-114**

1	TxD-(A)
2	TxD+(B)
3	RxD+(B)
4	RxD-(A)
5	GND
6	RTS-(A)
7	RTS+(B)
8	CTS+(B)
9	CTS-(A)

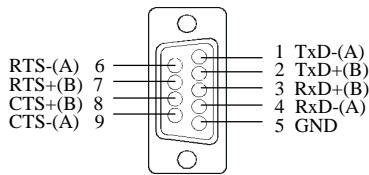

## Connection Cable and Cable Wiring

---

### RS-422 Point-to-point

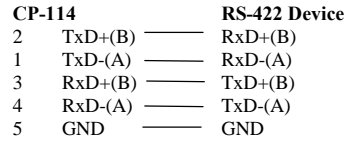

### RS-422 Broadcasting

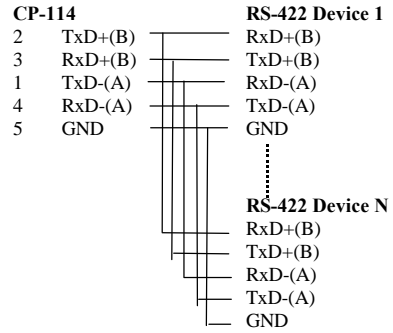

### RS-422 with Handshaking

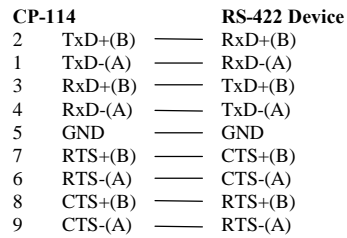

---

## RS-485 Cable Wiring

The RS-485 standard is an enhanced version of the RS-422 balanced line standard. It allows multiple drivers and receivers in a multidrop systems. As many as 32 drivers and 32 receivers can be put on any multidrop system.

The *Industio* CP-114 Series supports **only 2-wire half-duplex RS-485 communication**. **Data+/-** pins are served for both data transmitting and receiving, depending on the RTS signal.

RS-485 pin outs for the *Industio* CP-114 Series:

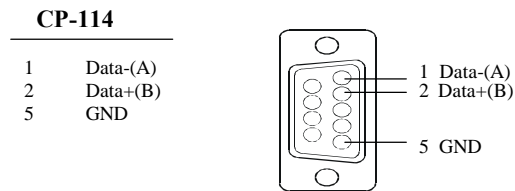

*Multidrop RS-485 Half-duplex*

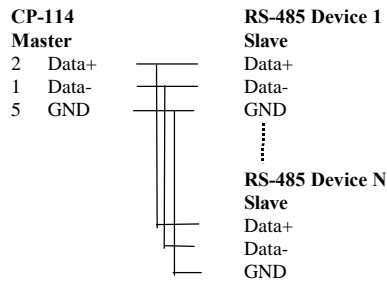

See the section “**RS-485 Programming**” of the chapter “**Serial Programming Tools**” for more RS-485 programming details.

## Impedance Matching and Termination Resistors

For RS-422/485 serial communications, when an electrical signal travels through two different resistance junctions in a transmission line, the impedance mismatch will sometimes cause signal reflection. Signal reflection causes signal distortion, which in turn will contribute communication errors. The solution to this problem is to establish the same impedance at the line ends as in the line itself by terminating them with resistors.

*Industio* CP-114 Series already installs the resistors on board for your convenience, indicated as follows. The value of the termination resistor should equal the characteristic impedance of the transmission line. Resistors should be added near the receiving side. **Note:** Stands for termination resistor near the receiving side.

CP-114 Series	RS-422/485 Device
2 TxD+(B)	RxD+(B)
1 TxD-(A)	RxD-(A)
3 RxD+(B)	TxD+(B)
4 RxD-(A)	TxD-(A)
7 RTS+(B)	CTS+(B)
6 RTS-(A)	CTS-(A)
8 CTS+(B)	RTS+(B)
9 CTS-(A)	RTS-(A)

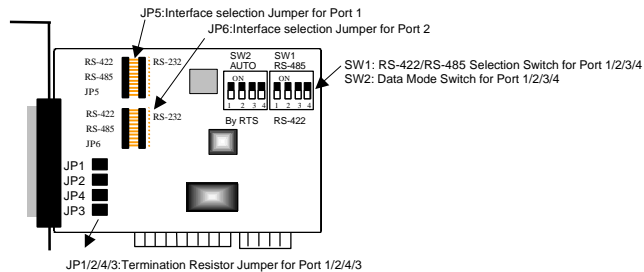

*Industio* CP-114 Series Board

---

## DB37 Connector

The following lists the pin assignments of the *Industio* CP-114 Series DB37 connector on the bracket. With this information, you may fabricate any type of fan-out cables, such as DB37 to DB9 x 4 or DB37 to DB25 x 4.

### For RS-232 Mode

Pin no.	Signal	Pin no.	Signal
29	RI2	19	TxD1
11	DCD2	30	DTR2
12	GND	31	DSR2
13	CTS2	32	RTS2
14	RxD2	33	TxD2
15	RI1	34	DCD1
16	DTR1	17	DSR1
36	CTS1	18	RTS1
37	RxD1		

**Note:** Make shield grounded to connector.

## Connection Cable and Cable Wiring

---

### For RS-422 Mode

Pin no.	Signal	Pin no.	Signal
1		20	CTS2-(A)
2	TxD2-(A)	21	RxD2-(A)
3	GND/VEE2	22	RTS2-(A)
4	CTS2+(B)	23	RTS2+(B)
5	TxD2+(B)	24	RxD2+(B)
6	CTS3-(A)	25	TxD3-(A)
7	RxD3-(A)	26	GND/VEE3
8	RTS3-(A)	27	CTS3+(B)
9	RTS3+(B)	28	TxD3+(B)
10	RxD3+(B)	29	CTS1-(A)
11	TxD1-(A)	30	RxD1-(A)
12	GND/VEE1	31	RTS1-(A)
13	CTS1+(B)	32	RTS1+(B)
14	TxD1+(B)	33	RxD1+(B)
15	CTS0-(A)	34	TxD0-(A)
16	RxD0-(A)	35	GND/VEE0
17	RTS0-(A)	36	CTS0+(B)
18	RTS0+(B)	37	TxD0+(B)
19	RxD0+(B)		

**Note:** Make shield grounded to connector.

### For RS-485 Mode

Pin no.	Signal	Pin no.	Signal
2	Data2-(A)	25	Data3-(A)
3	GND/VEE2	26	GND/VEE3
5	Data2+(B)	28	Data3+(B)
11	Data1-(A)	34	Data0-(A)
12	GND/VEE1	35	GND/VEE0
14	Data1+(B)	37	Data0+(B)

**Note:** Make shield grounded to connector.



# 6

## Troubleshooting

---

Common *Industio* CP-114 Series problems and possible solutions are listed below. If you still have problems, contact your dealer or Moxa for help. Or use the “**Problem Report Form**” at the end of this manual to report problems to your dealer at once for faster technical support.

### General Troubleshooting

1. **The MOXA driver, while installing the driver, cannot detect the MOXA PCI board.**

**Hardware causes and solutions:**

- a. The board is not installed or missing (absent). Please install it.
- b. The board is not properly plugged in the system. If that is the case, re-install the board and make sure that it fits well in a 32-bit PCI slot this time. Sometimes the slot for plugging the board is bad. In this case, try other slots until you find a good one.
- c. Your motherboard does not have a vacant IRQ for the CP-114 Series. Please enter BIOS and make sure there are available IRQ in PCI/PnP settings.

2. **The MOXA board and driver are activated but cannot transfer (transmitting/receiving) data.**

**Hardware Causes and Solutions:**

- a. Check for wrong cable wiring. Refer to the “Connection Cable and Cable Wiring” chapter for precise pinouts of the connector type you are using.
- b. The cables or the boards are defective. You may use other ports, cables or boards to verify. In addition, the *PComm* “Diagnostic” utility for Windows NT and Windows 95/98 is good for testing MOXA boards and port conditions. If Diagnostic reports error, replace the faulty components.

---

#### Software Causes and Solutions:

- a. For RS-422 mode, *Industio* CP-114 Series checks the line status (CTS) before it sends data out if the RTS/CTS flow control feature is set to “Enable” in the configuration or application program. Please refer to the “Connection Cable and Cable Wiring” chapter for proper wiring.
- b. Perhaps the application controlling the board is not correctly written according to the corresponding API of the operating system. To verify, please run an existing and known good application or the provided utilities by Moxa. For example, under Windows NT and Windows 95/98, *Pcomm* “Terminal emulator” or “HyperTerminal” utilities are good for testing the COM ports.

## Windows NT

This section is specific for troubleshooting under Windows NT. For general problems and solutions, please see the previous section, “General Troubleshooting”.

1. **After the system reboots, the error message “Another driver in the system, which did not report its resources, has already claimed the interrupt used by xxx.” appears in the Event Log.**

This indicates that the MOXA board is found, but the IRQ is conflicting with another adapter. Please make sure there is no conflict with other adapter’s IRQ. Check the PCI BIOS IRQ settings first. Make sure that an IRQ is available.

2. **After the system reboots, the error message “Cannot find any configured MOXA *Smartio*/Industio PCI Series board!” appears in the Event Log.**

Please make sure the PCI board is seated firmly in the expansion slot.

3. **The COM number of the *Industio* CP-114, with device number xx, conflicts with others.**

The COM numbers of different boards happen to be the same. Try to change the COM number mappings.

4. **Windows NT system panic (blue screen).**

The possible reason is an IRQ or I/O address conflict with other ISA Bus adapters, like LAN and SCSI boards, or the system BIOS. Please refer to the corresponding problem in the previous section, “General Troubleshooting”, for solutions.

### Windows 95/98

This section is specific for troubleshooting under Windows 95/98. For general problems and solutions, please see the previous section, “General Troubleshooting”.

**1. The system fails to find the *Industio* CP-114 board!**

- The board(s) is not plugged properly.
  - The slot for plugging the board is defective.
- In this case, please try other slots until you find a good one.
- The board might be defective.

**2. After the system reboots, the error message “CP-114 (BusNo=x, DevNo=x, Port1=COMx) interrupt number is invalid!” appears.**

This indicates that the MOXA board is found, but the IRQ is conflicting with other adapter. Make sure MOXA board's IRQ is not conflicting with other adapter's. Check the PCI BIOS IRQ settings and select an available IRQ for MOXA boards.





## Technical Reference

### Specification

- ❖ Bus interface: 32-bit PCI (Spec 2.1)
- ❖ Number of ports: 2 (RS-232 or RS-422/485), 2 (RS-422/485)
- ❖ I/O address: Assigned by BIOS
- ❖ IRQ: Assigned by BIOS
- ❖ Data bits: 5, 6, 7, 8
- ❖ Stop bits: 1, 1.5, 2
- ❖ Parity: None, even, odd, space, mark
- ❖ UART: 16C550C or compatible × 4, each with 16byte Tx/Rx FIFO
- ❖ Speed (bps): 50 ~ 921.6K
- ❖ Connectors: DB9 (male) × 4
- ❖ Data signals: RS-232 - TxD, RxD, RTS, CTS, DTR, DSR, DCD, GND  
RS-422 - TxD(B)+/(A)-, RxD(B)+/(A)-, RTS(B)+/(A)-, CTS(B)+/(A)-, GND  
RS-485 - Data(B)+/(A)-, GND
- ❖ Isolation protection: Max. 2000V (CP-114I, CP-114IS)
- ❖ Surge protection: ESD 25KV (CP-114S, CP-114IS)
- ❖ Operating temp: 0 ~ 55
- ❖ Regulation Approval: CE, FCC Class A
- ❖ OS supported: Windows NT, Windows 95/98, DOS
- ❖ Termination resistor: RS-422: 120 Ohm  
RS-485: 120 Ohm, jumper enable/disable
- ❖ Power requirement: CP-114: 720mA max. (+5V), 43mA max. (+12V), 31mA max. (-12V)  
CP-114S: 735mA max. (+5V), 44mA max. (+12V), 33mA max. (-12V)  
CP-114I: 1164mA max. (+5V), 35mA max. (+12V), 48mA max. (-12V)  
CP-114IS: 1170mA max. (+5V), 36mA max. (+12V), 49mA max. (-12V)
- ❖ Dimensions: CP-114/CP-114S: 135 mm × 110 mm  
CP-114I/CP-114IS: 160 mm × 120 mm

### PCI

The 32-bit *Industio* CP-114 Series board complies with the PCI specifications 2.1. Hardware

---

configuration for IRQ and I/O addresses is automatically assigned by the PCI BIOS. Hence, you must **first plug the board** before installing the software driver.

Unlike ISA slots, different PCI slots in the same PC may have different bus numbers and device numbers with respect to the PCI specifications. The same PCI board will have different system configurations if switching to a different PCI slot, which may be called **slot-sensitive** or **slot-dependent**. This may also apply to PCI slots in PC with different motherboard, which may use **different device number sets**. For example, some use 17, 18, 19, and 20 for identifying the respective PCI slots but some use 11, 12, 13 and 14.

Due to the **slot-dependency**, it is necessary to **re-configure the software driver** once the board is plugged in different PCI slots.

Up to 4 *Industio* CP-114 Series boards are allowed in one system. When installing more than one board, **please remember the order of boards** for distinguishing the installed boards.

## UART 16C550C

The UART chip, **16C550C**, is an intelligent asynchronous controller capable of supporting one full duplex channel that simultaneously transfers data at **921.6 Kbps**. To increase the overall data throughput, special features such as on-chip FIFO and on-chip hardware flow control are used to reduce the number of interrupts to the onboard CPU and to prevent any loss of valuable data.

## Problem Report Form

### *Industio* CP-114 Series

<b>Customer name:</b>	
<b>Company:</b>	
<b>Tel:</b>	<b>Fax:</b>
<b>Email:</b>	<b>Date:</b>

1. **Moxa Product:** CP-114 Series **Model :** CP-114 CP-114I CP-114S CP-114IS  
**Serial Number:** \_\_\_\_\_

2. **Moxa Driver Version:** \_\_\_\_\_

3. **Moxa Hardware Settings:** PCI slot number \_\_\_\_\_

4. **Operating System:**  Windows 95  Windows 98  
 Windows NT 3.51  Windows NT 4.0  
 DOS  Others

5. **PC Host:** Make \_\_\_\_\_ Model \_\_\_\_\_

6. **CPU:** Speed \_\_\_\_\_MHz Make \_\_\_\_\_ Model \_\_\_\_\_

7. **BIOS:** Make \_\_\_\_\_ Version \_\_\_\_\_

8. **PCI IRQ Configuration in BIOS:**

PORT	1	2	3	4
I/O				
IRQ				
Interface (RS-232/422/485)				
RS-485 Data Mode (ADDC/RTS)				

9. **Problem Description:** Please describes the problem as clearly as possible, including the error message you see. We may have to follow your description to reproduce the problem.

- Board not found.  Board found, but can't transfer data.  
 Can transfer data, but lose data.  Can transfer data, but with garbled data.  
 Others. Detailed error message description is recommended:

## **Return Procedure**

For product repair, exchange or refund, you must:

- ❖ Provide evidence of original purchase.
- ❖ Fill out the Problem Report Form (PRF) as detailed as possible for shorter product repair time.
- ❖ Obtain a Return Merchandise Authorization (RMA) number from the sales representative or dealer.
- ❖ Carefully pack the product in an anti-static package, and send it, pre-paid, to the dealer. The RMA number should be visible on the outside of the package, and include a description of the problem along with the return address and telephone number of a technical contact.