

# RS-232 RACK MOUNT PORT COMBINER

Models RMPTC & RBP113

Document No. RMPTC3097

## Introduction

B&B Electronics Model RMPTC is an industrial rack mount version of our RS-232 Port Combiner. It permits two or more serial devices to share a serial port on a host computer. When one of the devices on either of the slave ports transmits data, it captures the data path to the master port and locks out the other slave port. When data transmission is finished, either slave port gets access to the master port by being the first to start sending data again or by raising its RTS line. The RMPTC can cascade slave ports to combine as many devices as needed into one host port. A typical application would be to share one host port with several terminals, scanners, scales, or other devices that would need only occasional access to the host port. (Figure 1)

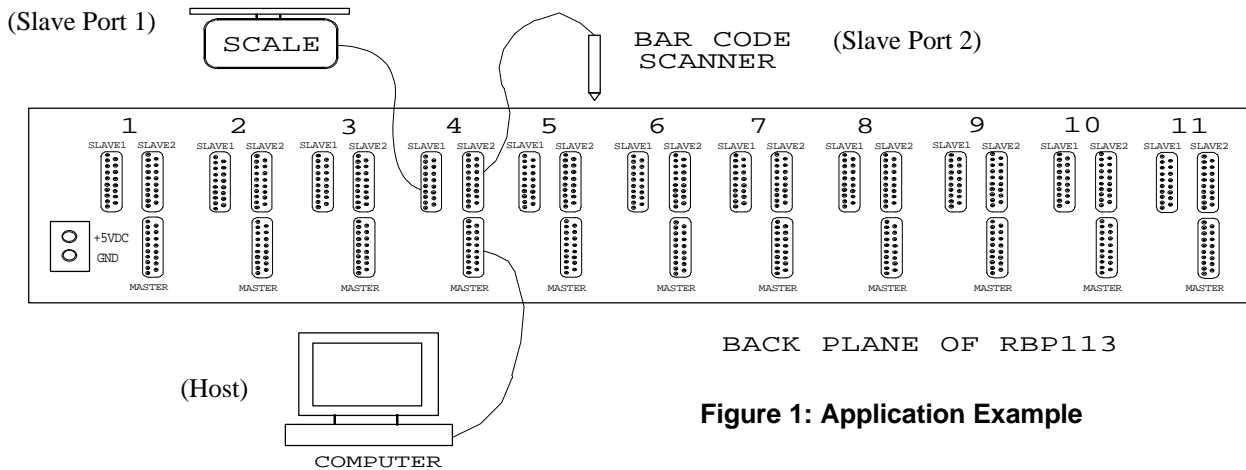
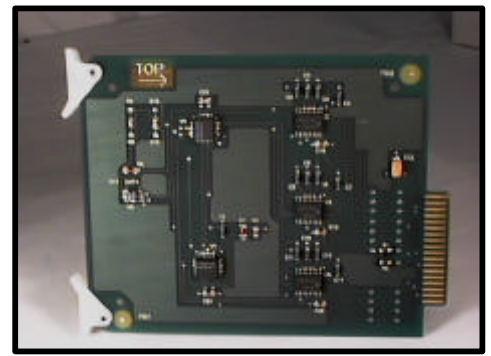

Figure 1: Application Example

## Operation

### Data Flow from master port to slave ports

All data that is sent to the TX line, pin 2 on the master port, is broadcast to both slave ports under all conditions. This data appears on pin 3 of each slave device.

### Data flow from slave ports to master port

Data that is sent to the TX line (pin 2) on the slave ports must compete for the path to the master port. There are two methods of capturing the path to the master port, RTS and automatic data sensing. The first slave port to either raise its RTS line or transmit data captures the path to the master port. The path will be locked on that slave port until it either lowers its RTS line, or 50 milliseconds after the end of its data transmission. NOTE: the RMPTC does not buffer any data. Any data sent to the opposite slave port during this period will be lost. The 50ms timeout period can be modified. Contact B&B's technical support for further information.

## Handshake Signals

The CTS signal on each slave port indicates to the slave devices if the path to the master port is available. If the slave port's CTS line is high, data received by that port will be transmitted out the master port. If CTS is low, the opposite slave port has captured the path to the master and any data at the inactive slave port will be lost. For example, if both slave ports are inactive and have RTS low, CTS will be high at both slave ports, indicating that the path is available. As soon as one slave port captures the path by either beginning its transmission or raising its RTS line, the CTS signal at the opposite slave port will drop to the low state.

The CTS output on the pin 5 of the master port follows the RTS signal level found on the active slave port.

## Pinouts

All ports on the RMPTC are configured as RS-232 DCE ports, using DB-25 female connectors. Note that a null-modem type connection will be required to connect the RMPTC to other DCE configured ports. Tables 1 and 2 and Figure 1 show the configuration of each port.

**Table 1  
Master Port Pinouts**

Signal	Pin	Direction
TD	2	Input
RD	3	Output
CTS	5	Output

**Table 2  
Slave Port Pinouts**

Signal	Pin	Direction
TD	2	Input
RD	3	Output
RTS	4	Input
CTS	5	Output
GND	7	-----

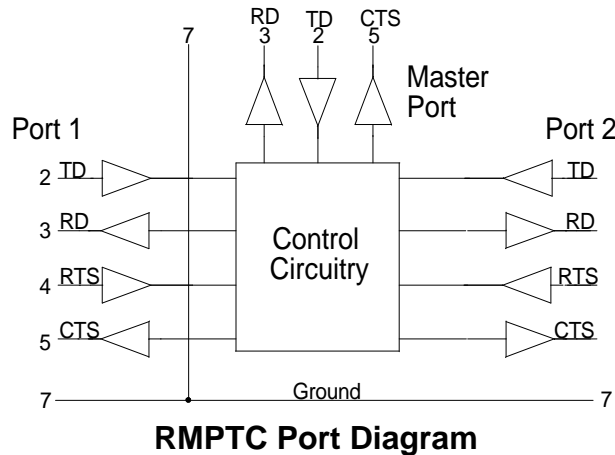

## Cascading Port Combiners

Port combiners can be cascaded with a null modem cable by connecting the master port of each successive unit to one of the slave ports of the preceding unit. Each additional port combiner adds one slave port to the system.

## RMPTC in RBP113 Rack

Up to 11 RMPTC's can be placed in the RBP113 rack. The RBP113 rack has a back plane that includes three DB-25 female connectors for each of the 11 RMPTC's. The back plane is also fitted with plug in terminal blocks to bring in a regulated +5VDC and ground to the RMPTC's. A 36 pin edge connector provides access from each card to the back plane, allowing for easy plug in replacement of the cards from the front of the enclosure.

NOTE: RMPTC cards can be inserted into or removed from the RBP113 without disconnecting power from the RBP113.

## Specifications

### RMPTC

Dimensions: 5.535"W x 4.500"H x 0.065D"  
 Connectors: 36 contact edge connector  
 Power Supply: Requires regulated 5VDC  
 Current Draw: 175mA per RMPTC  
 Operating Temp: 0-50 °C  
 Signals: TD, RD, RTS (slave to master only)  
 CTS indicates open channel (slave only)

### RBP113

Power Supply: Plug-in terminal block for power (regulated +5VDC)  
 Dimensions: 19"W x 5.25"H x 9"  
 Connectors: (3) DB-25 female connectors per card, RS-232 DCE configuration